

# IPE-305: **M**ANUFACTURING **P**ROCESSES - II

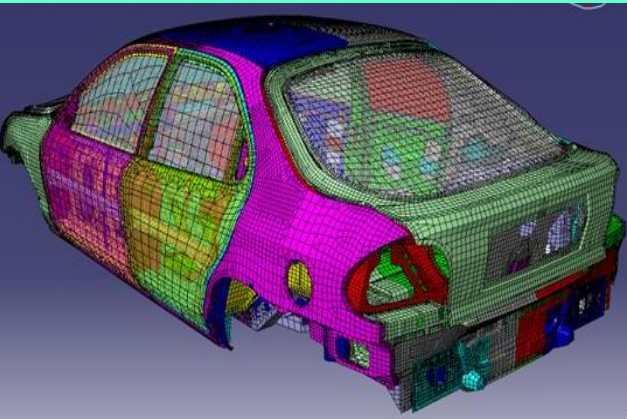

Artificial Heart Valves



Example of a mechanical valve



Example of a tissue valve

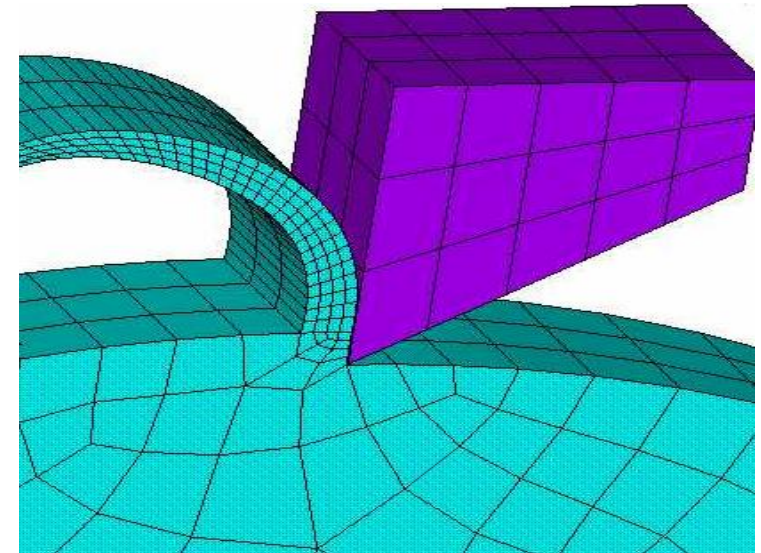
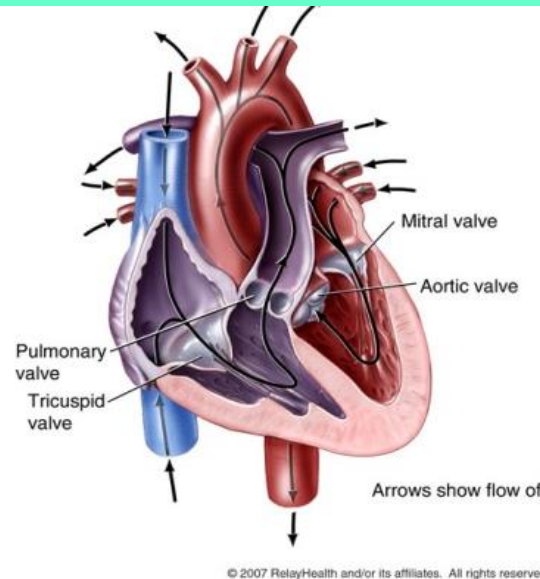

**DR. NIKHIL R. DHAR**

Professor, IPE Department

BUET

# Course Outlines

---

- Conventional Machining Processes: Turning and Related Operations, Drilling and Related Operations, Milling and Related Operations, Shaping and Related Operations, Grinding and Related Operations. [Q-2(A)]
- Theory of Metal Cutting: Tool geometry, Chip formation, Mechanics of metal cutting, Cutting tool material, Cutting fluid and Machining economics. [Q-1(A)]
- Modern Machining Processes: Abrasive Jet Machining, Water Jet Machining, Ultrasonic Machining, Electrochemical Machining, Electrical Discharge Machining, Laser Beam Machining, Electron Beam Machining. [Q-2(B)]
- Processes for Plastic Products: Injection molding, Compression molding, Blow molding, Transfer molding, Compounding, Extrusion, Vacuum forming, Thermo-forming etc. [Q-2(B)]
- Selection of Manufacturing Processes on the basis of product characteristics and manufacturing economy. [Q-1(A)]



# Suggested Reading

## ■ Text Book

- Manufacturing Processes for Engineering Materials - S. Kalpakjian & S. R. Schmid
- Materials and Processes in Manufacturing - E.P. Degarmo, J.T. Black & R.A. Kohser
- Fundamentals of Modern Manufacturing - M.P. Groover
- Processes and Design for Manufacturing - S.D.EI Wakil
- Metal Cutting Principles - M. C. Shaw
- Metal Cutting - E. Trent
- Manufacturing Technology – B. Kumar

## ■ Journals

- CIRP Annals
- JSME International Journal
- Journal of Advanced Manufacturing Technology
- Journal of Material Processing Technology
- ASME
- Wear
- IMechE



# Marks Distribution

## ■ Total Marks: 300

Class Test (20%)				Class Attendance [10%]	Final Examination [70%]
1	2	3	4		
20	20	20	20	30	210

Quiz-01 : Conventional Machining

Quiz-02 : Conventional Machining [Extra]

Quiz-03 : Theory of Metal Cutting-Chip Formation & Cutting Forces

Quiz-04 : Modern Machining Processes

Quiz-05 : Processes for Plastic Products



# LECTURE-01:

# CONVENTIONAL MACHINING

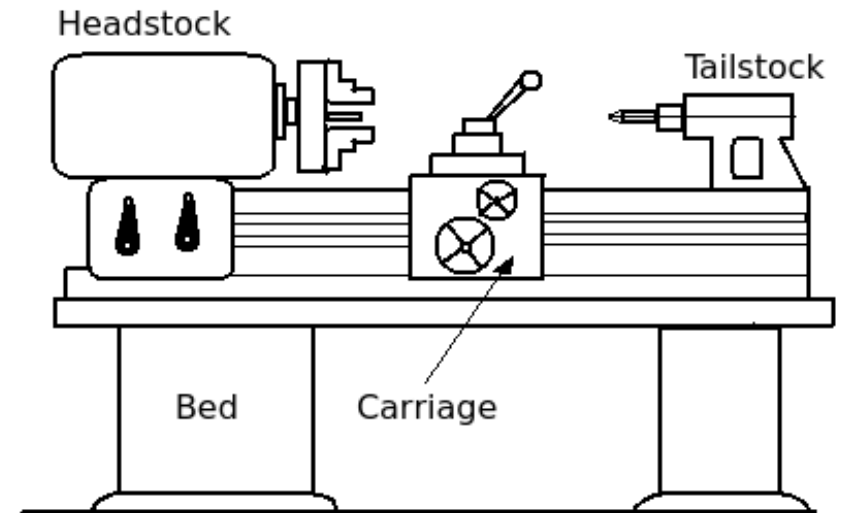
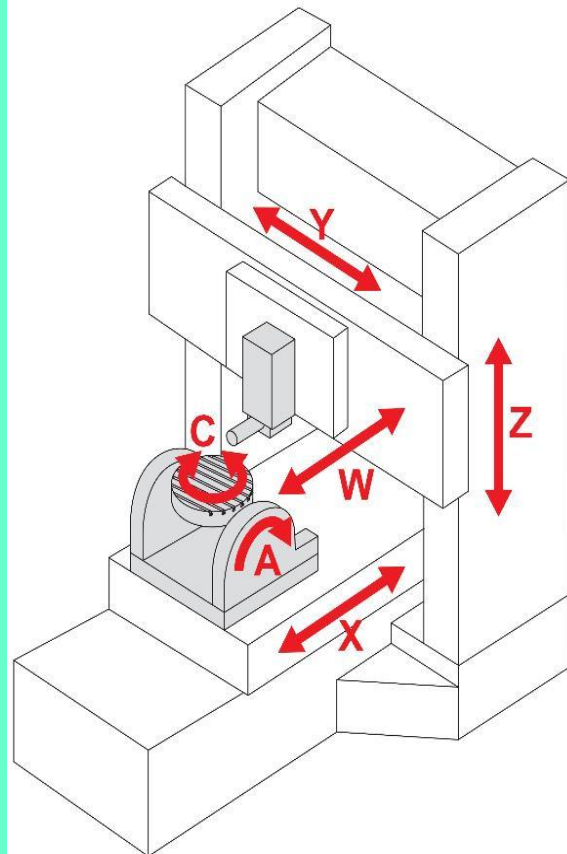

**DR. NIKHIL R. DHAR**

Professor, IPE Department  
BUET

# Introduction

---

- Machining is an essential process of **semi-finishing** and **often finishing** by which jobs of desired shape and dimensions are produced by **removing extra material** from the preformed blanks in the form of chips with the help of cutting tools moved past the work surfaces in machine tools. Machined parts can be classified as rotational or non-rotational.
- A **rotational workpart** has a cylindrical or disk-like shape. The characteristic operation that produces this geometry is one in which a cutting tool removes material from a rotating workpart. Examples include turning and boring. Drilling is closely related except that an internal cylindrical shape is created and the tool rotates in most **drilling** operations.
- A **non-rotational** (also called prismatic) workpart is block-like or plate-like. This geometry is achieved by linear motions of the workpart, combined with either rotating or linear tool motion. Operations in this category include **milling**, **shaping**, **planing** and **sawing**



- 
- 
- Each machining operation produces a characteristics geometry due to two factors
    - the relative motions between the tool and the workpart and
    - the shape of the cutting tool. These operations may be classified as **generating** and **forming**.
  - In **generating**, the geometry of the workpart is determined by the feed trajectory of the cutting tool. Examples of generating the work shape in machining include **straight turning, taper turning, contour turning, peripheral milling and profile milling**.
  - In **forming**, the shape of the part is created by the geometry of the cutting tool. In effect, the cutting edge of the tool has the reverse of the shape to be performed on the part surface. **Form turning, drilling, and broaching** are examples of the case.
  - Forming and generating are sometimes combined in one operation, such as in **thread cutting** on a lathe and **slot milling**.



# Example of Generating and Forming

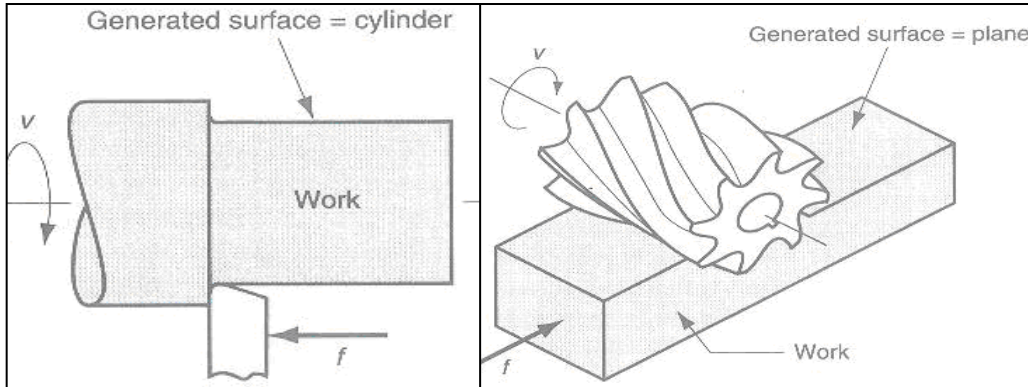

**Straight Turning**

**Plain Milling**

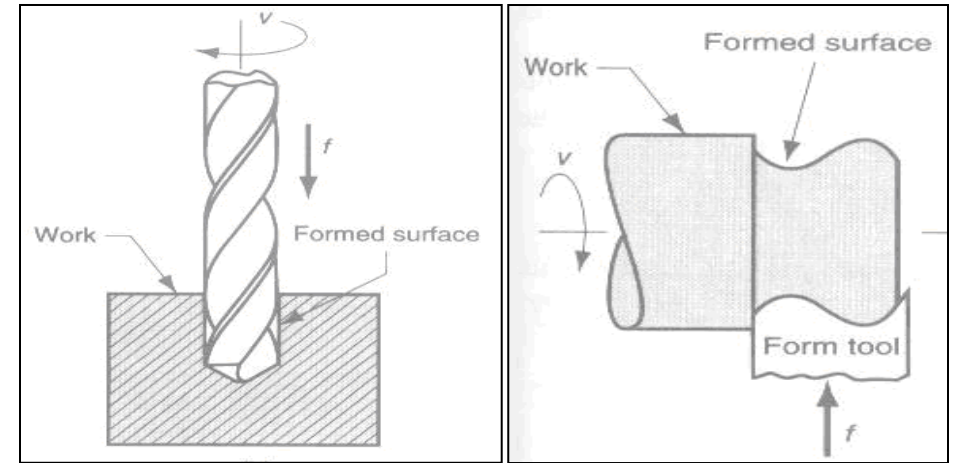

**Drilling**

**Form Turning**

## Forming Shape in Machining

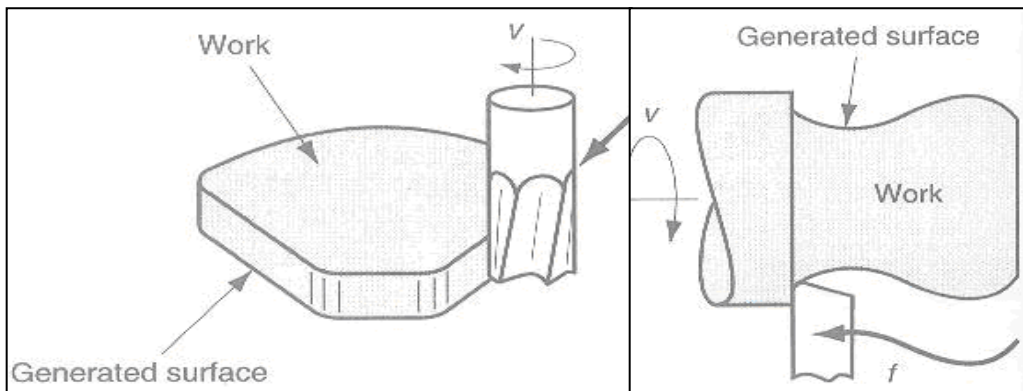

**Profile Milling**

**Contour Turning**

## Generating Shape in Machining

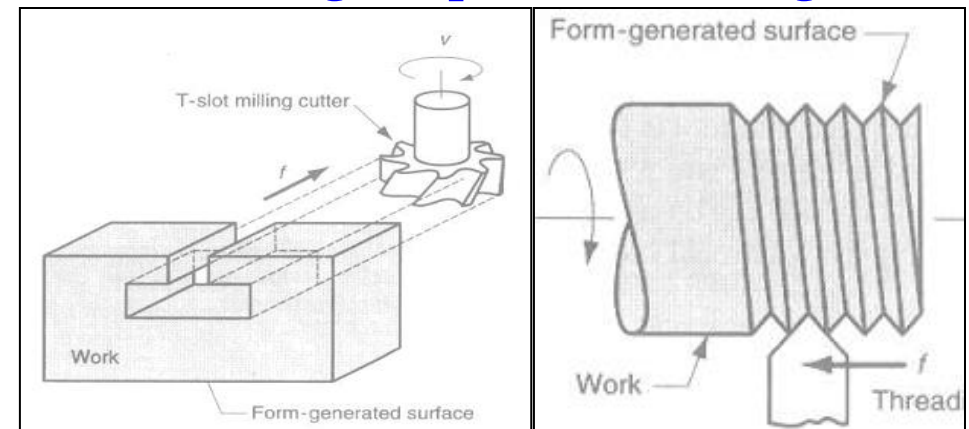

**Slot Milling**

**Thread Cutting**

## Combination of Forming and Generating



# Turning and Related Operations

- Turning is the process whereby a centre lathe is used to produce "**solids of revolution**". It can be done manually, in a traditional form of lathe, which frequently requires continuous supervision by the operator, or by using a computer controlled and automated lathe which does not. This type of machine tool is referred to as having **computer numerical control (CNC)** and is commonly used with many other types of machine tool besides the lathe.
- When turning, a piece of material is rotated and a cutting tool is traversed along 2-axes of motion to produce precise diameters and depths. Turning can be either on the **outside of the cylinder** or on the **inside** (also known as **boring**) to produce tubular components to various geometries. It is said that the lathe is the only machine tool that can reproduce itself.

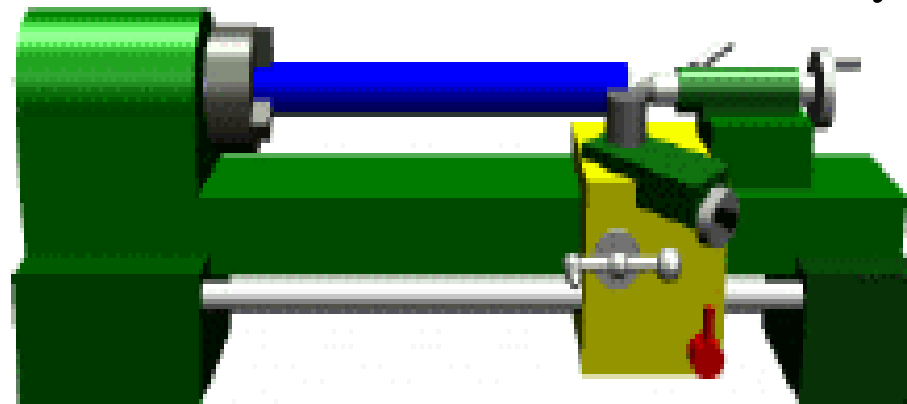

# Basic Turning Operations

- **Facing**: The tool is fed radially into the rotating work on one end to create a flat surface on the end.
- **Taper Turning**: Instead of feed the tool parallel to the axis of rotation of the work, the tool is fed at an angle, thus creating a taper cylinder or conical shape.
- **Contour Turning**: Instead of feeding the tool along a straight line parallel to the axis of rotation as in turning, the tool follows a contour that is other than straight, thus creating a contoured form in the turned part.
- **Form Turning**: In this operation, sometimes called forming, the tool has a shape that is imparted to the work by plunging the tool radially into the work.
- **Chamfering**: The cutting edge of the tool is used to cut an angle on the corner of the cylinder, forming what is called a “chamfer”.

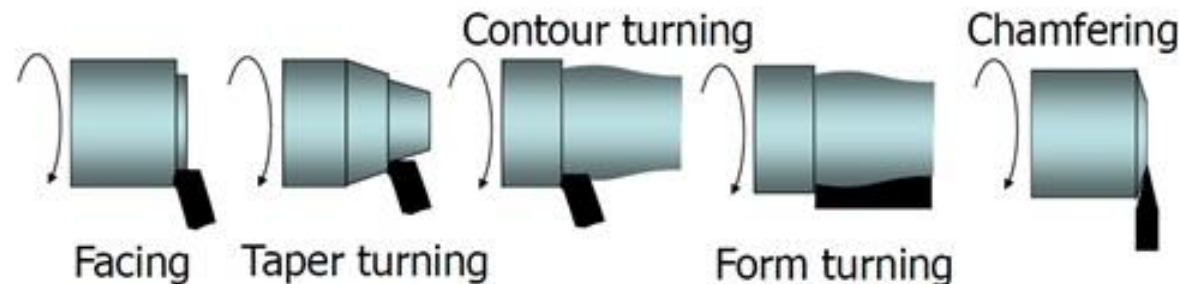

- **Cutoff:** The tool is fed radially into the rotating work at some location along its length to cut off the end of the part. This operation is sometimes referred to as parting.
- **Threading:** A pointed tool is fed linearly across the outside surface of the rotating workpiece in a direction parallel to the axis of rotation at a large effective feed rate, thus creating threads in the cylinder.
- **Boring:** A single point is fed linearly parallel to the axis of rotation, on the inside diameter of an existing hole in the part.
- **Drilling:** Drilling can be performed on a lathe by feeding the drill into the rotating work along its axis. Reaming can be performed in a similar way.
- **Knurling:** This is not a machining operation because it does not involve cutting of material. Instead, it is a metal forming operation used to produce a regular cross hatched pattern in the work surface.

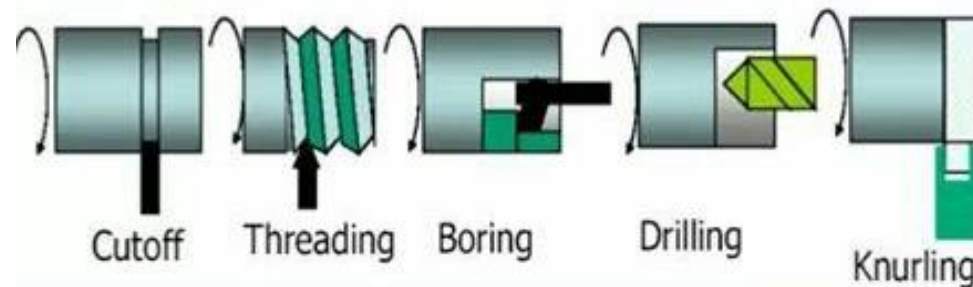

# Types of Lathe

---

## ■ Speed Lathes

- Limited to headstock, tailstock, and simple tool post.
- Limited to 3-4 speeds
- High spindle speeds,
- For light work such as wood turning, metal polishing, or metal spinning

## ■ Engine Lathes

- Most common type
- Variable in design from low to high power designs
- Broad range of lengths up to 60ft long

## ■ Tool Room Lathes

- Specialized Engine lathe with greater accuracy.
- Broader range of speeds and feeds
- Greater versatility for tool and die manufacturing

## ■ Turret Lathes

- Turret on tool post rotates to position a variety of tools
- Capstan wheel used to pull tool away from work piece to position next tool
- A number of tools set up on machine, each brought up in quick succession to complete the part in a single setup



## ■ Lathe Components:

- **Bed:** Supports all major components
- **Carriage:** Slides along the ways and consists of the cross-slide, tool post, apron
- **Headstock:** Holds the jaws for the work piece, supplies power to the jaws and has various drive speeds
- **Tailstock:** Supports the other end of the workpiece
- **Feed Rod and Lead Screw:** Feed rod is powered by a set of gears from the headstock

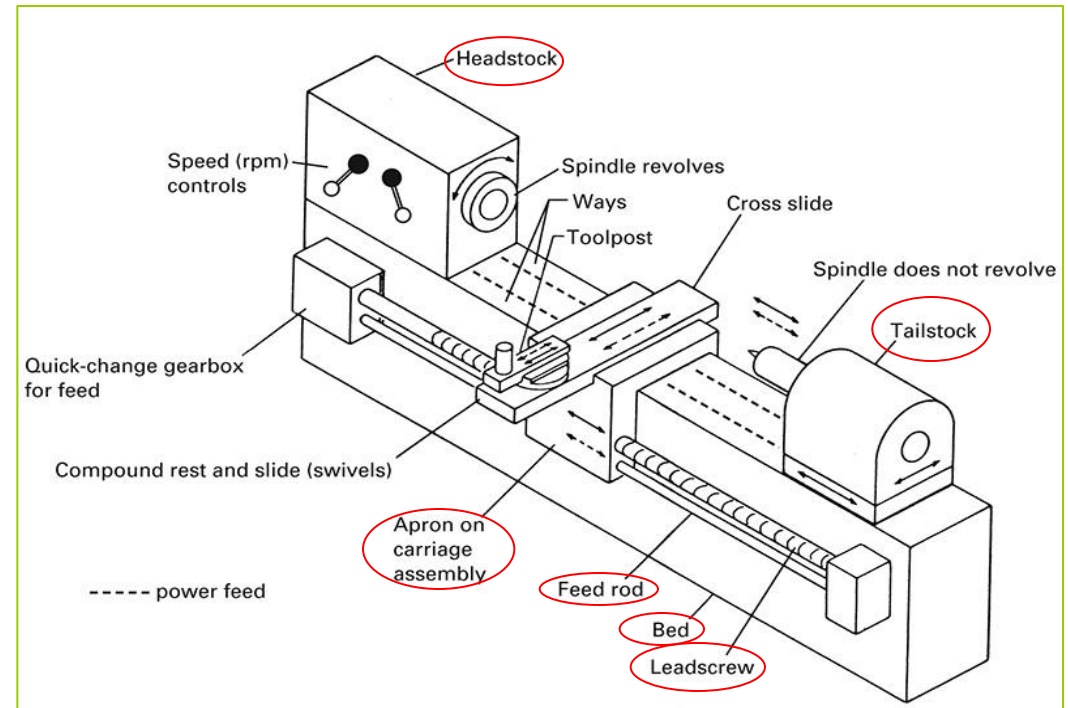

# Work Holding Devices for Lathes

---

- Work pieces can be held by various methods
  - Work piece mounted between centers
  - Work piece mounted within a single chuck
  - Work piece mounted within a collet
  - Work piece mounted on a faceplate
- Lathe Centers: A lathe center hold the end of the work piece, providing support to preventing the work piece from deflecting during machining
- Lather centers can be mounted in the spindle hole, or in the tailstock quill
- Lathe centers fall into two categories
  - **Dead Center**: solid steel tip that work piece spins against
  - **Live Center**: centers contact point is mounted on bearings and allowed to spin with work piece



# Lathe Chucks

- Lathe Chucks are adjustable mechanical vises that hold the work piece and transfer rotation motion from the drive motor to the work piece. Lathe Chucks come in two basic types

- Three-jaw Self-centering Chucks

- Used to center round or hexagonal stock

- Four-jaw Independent Chucks

- Each jaw moves independently to accommodate various work piece shapes

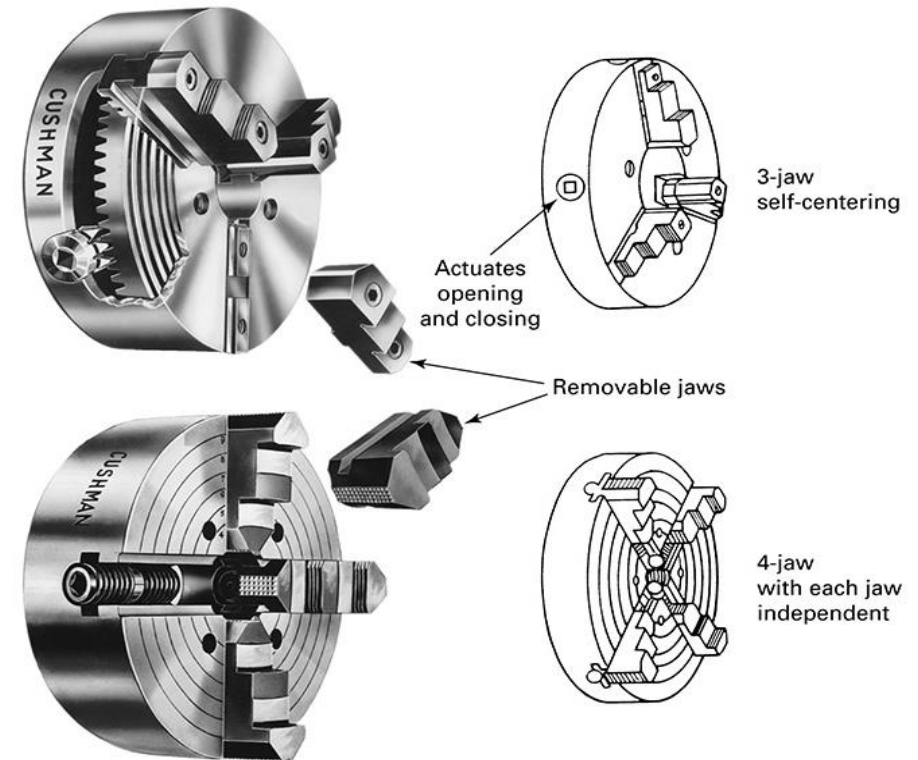

# Lathe Collets

- Collets are used to **hold round stock** of standard sizes. Most accurate holding method for round stock
  - Run out less than 0.0005 inch
  - Stock should be no more than 0.002 inch larger or 0.005 smaller than the collet
  - Typically used for **drill-rod, cold-rolled, extruded, or previously machined stock**

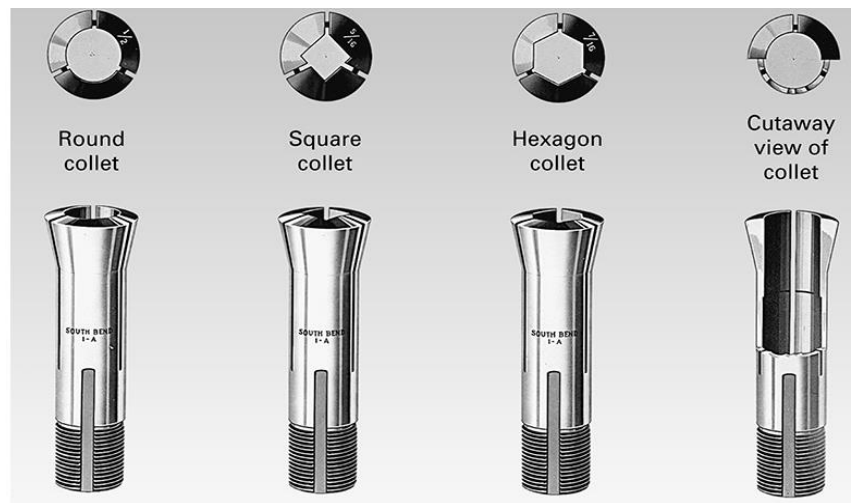

Several types of lathe collets



## ■ Reaming:

- Reams remove small amounts of material to ensure exact hole size and improve hole surface finish
- Reams are either hand operated or machined at slow speed

## ■ Ream Types

- Shell reams
- Expansion reams
- Adjustable reams
- Tapered reams

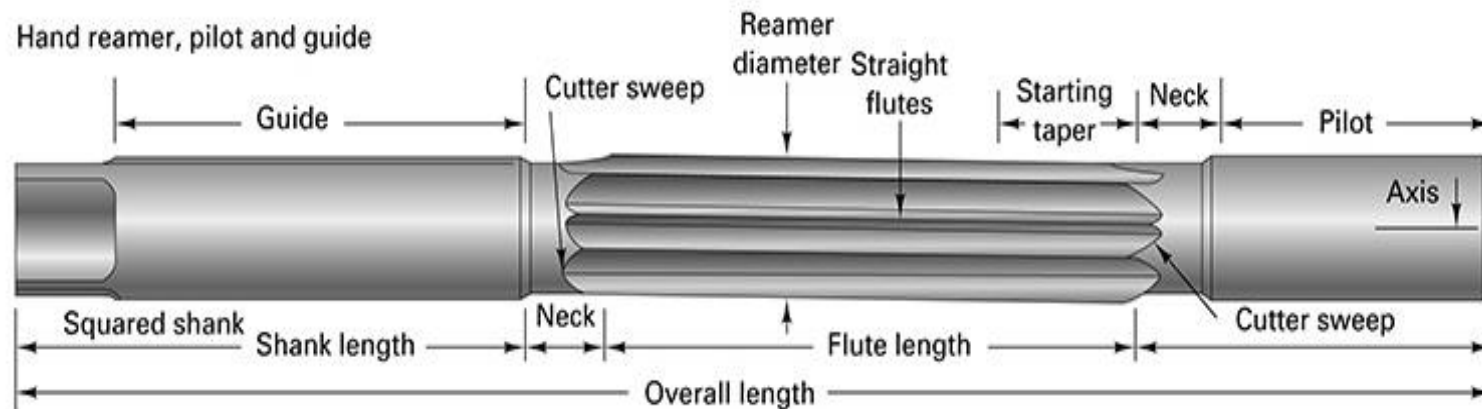

- **Boring:** Boring consists of producing circular internal profiles in hollow workpieces or on a hole made by drilling or another process and is carried out using cutting tools that are similar to those used in turning. However, because the boring bar has to reach the full length of the bore, tool deflection and hence maintenance of dimensional accuracy can be a significant problem. A vertical boring machine is similar to a lathe is shown in the following Figure.

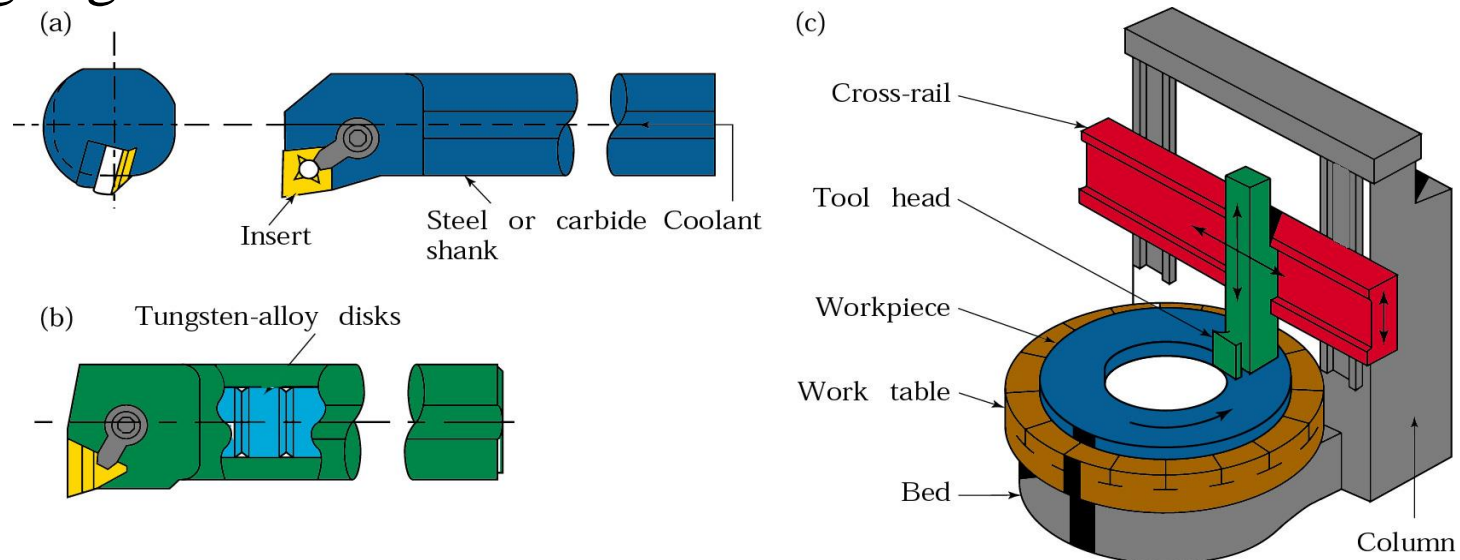

# Milling and Related Operations

- A milling machine removes metal by rotating a multipoint cutting tool against the workpiece. The cutting tool is held in position by the arbor and has no other motion except rotation. The workpiece is held on a table which controls the feed against the tool. In most milling machines, there are three possible table movements, **longitudinal**, **crosswise** and **vertical**, but in some cases the table may also possess **swivel** or **rotational** movement.
- Milling machine is one of the most versatile conventional machine tools with a wide range of metal cutting capability. Many **complicated operations** such as **indexing**, **gang milling**, and **straddle milling** etc. can be carried out on a milling machine.

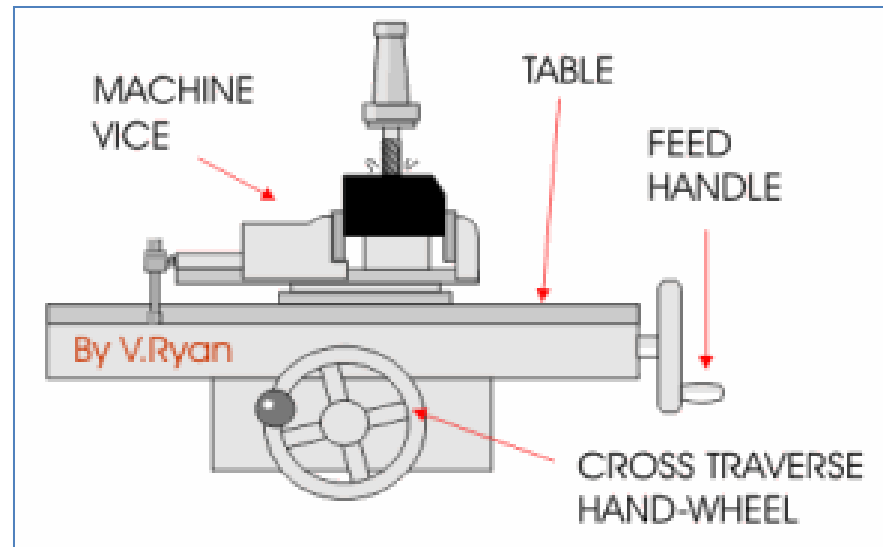

# Methods of Cutting

- Up Milling: In up cut milling, the cutter rotates in a direction opposite to the table feed. It is conventionally used in most milling operations because the backlash between the lead screw and the nut of the machine table can be eliminated.
- Down Milling: In down cut milling, the cutter rotates in the same direction as the table feed. This method is also known as **Climb Milling** and can only be used on machines equipped with a backlash eliminator or on a **CNC milling machine**. This method, when properly treated, will require less power in feeding the table and give a better surface finish on the workpiece.

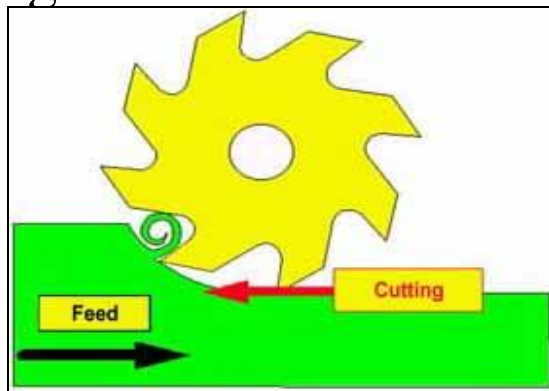

**Up Cut Milling**

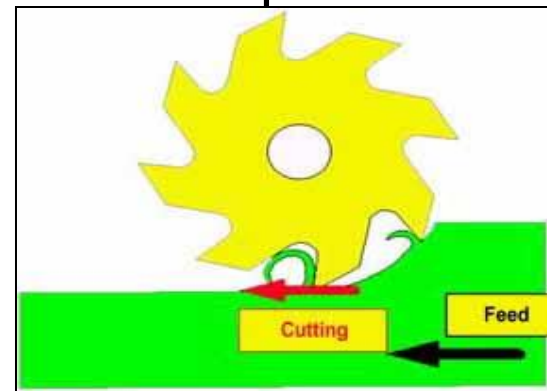

**Down Cut Milling**



# Classification of Milling Machines

- Column and Knee Type Milling Machines: Used for general purpose milling operations, column and knee type milling machines are the most common milling machines. The spindle to which the milling cutter is may be (i) **Horizontal Milling Machine** and (ii) **Vertical Milling Machine**.
- Bed type Milling Machines: In bed type machines, the work table is mounted directly on the bed, which replaces the knee, and can move only longitudinally. These machines have high stiffness and are used for high production work.
- Planer Milling Machines: Planer machines are similar to bed type machines but are equipped with several cutters and heads to mill various surfaces.
- Rotary Table Milling Machines: Rotary table machines are similar to vertical milling machines and are equipped with one or more heads to do face milling operations.
- Tracer Controlled Milling Machines: Tracer controlled machines reproduce parts from a master model. They are used in the automotive and aerospace industries for machining complex parts and dies.
- CNC Milling Machines: Various milling machine components are being replaced rapidly with computer numerical control (CNC) machines. These machine tools are versatile and are capable of **milling**, **drilling**, **boring** and **tapping** with repetitive accuracy.



---

---

## ■ Horizontal Milling Machine

- Column: The column houses the spindle, the bearings, the gearbox, the clutches, the shafts, the pumps, and the shifting mechanisms for transmitting power from the electric motor to the spindle at a selected speed.
- Knee: The knee mounted in front of the column is for supporting the table and to provide an up or down motion along the Z axis.
- Saddle: The saddle consists of two slideways, one on the top and one at the bottom located at  $90^\circ$  to each other, for providing motions in the X or Y axes by means
- Table: The table is mounted on top of the saddle and can be moved along the X axis. On top of the table are some T-slots for the mounting of workpiece or clamping fixtures.
- Arbor: The arbor is an extension of the spindle for mounting cutters. Usually, the thread end of an arbor is of left hand helix.



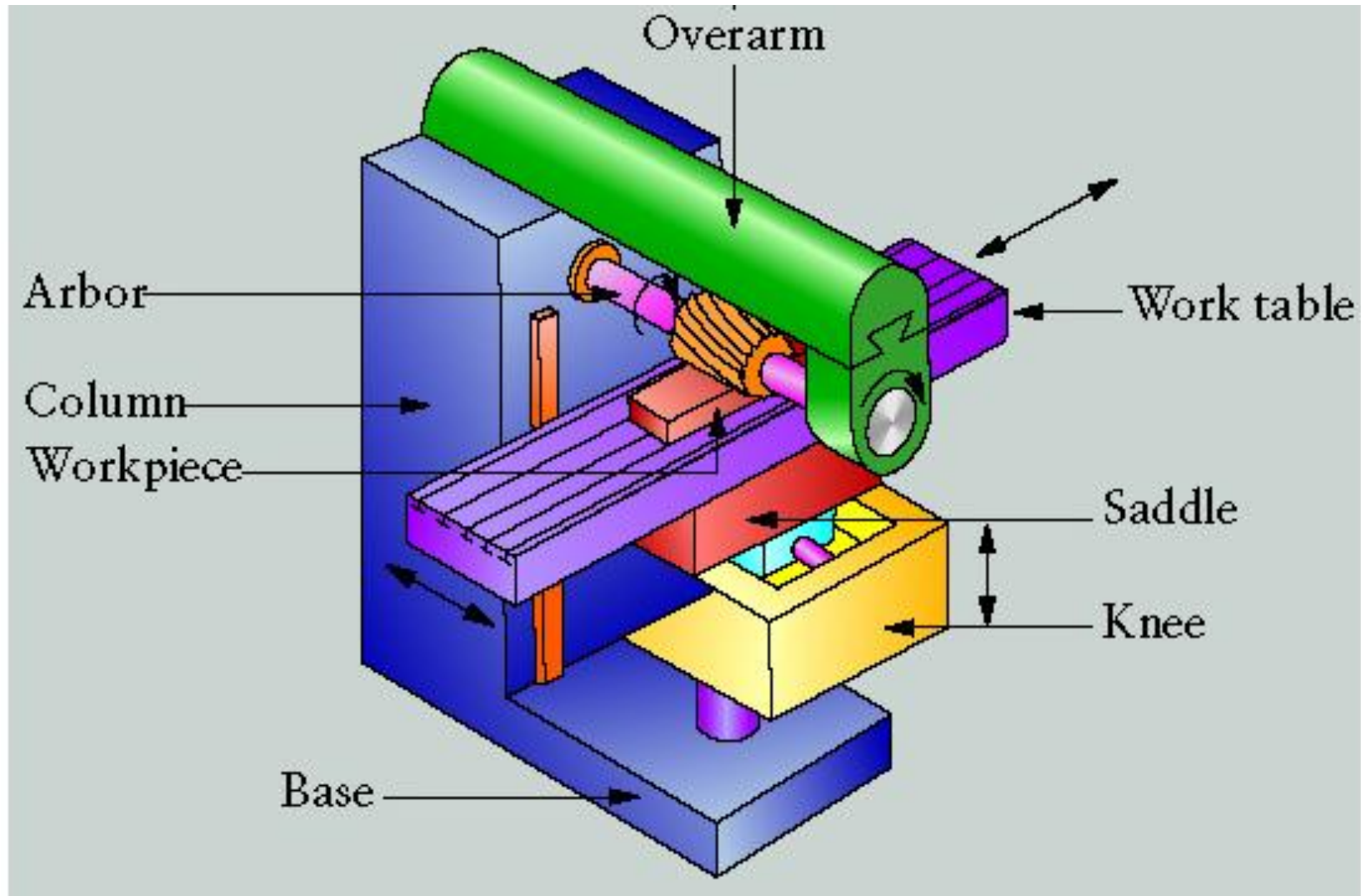

## ■ Vertical Milling Machine

- Column: The column houses the spindle, the bearings, the gearbox, the clutches, the shafts, the pumps, and the shifting mechanisms for transmitting power from the electric motor to the spindle at a selected speed.
- Knee: The knee mounted in front of the column is for supporting the table and to provide an up or down motion along the Z axis.
- Saddle: The saddle consists of two slideways, one on the top and one at the bottom located at  $90^\circ$  to each other, for providing motions in the X or Y axes by means of lead screws.
- Table: The table is mounted on top of the saddle and can be moved along the X axis. On top of the table are some T-slots for the mounting of workpiece or clamping fixtures.
- Milling Head: The milling head consisting the spindle, the motor, and the feed control unit is mounted on a swivel base such that it can be set at any angle to the table.
- Ram: The ram on which the milling head is attached can be positioned forward and backward along the slideways on the top of the column.



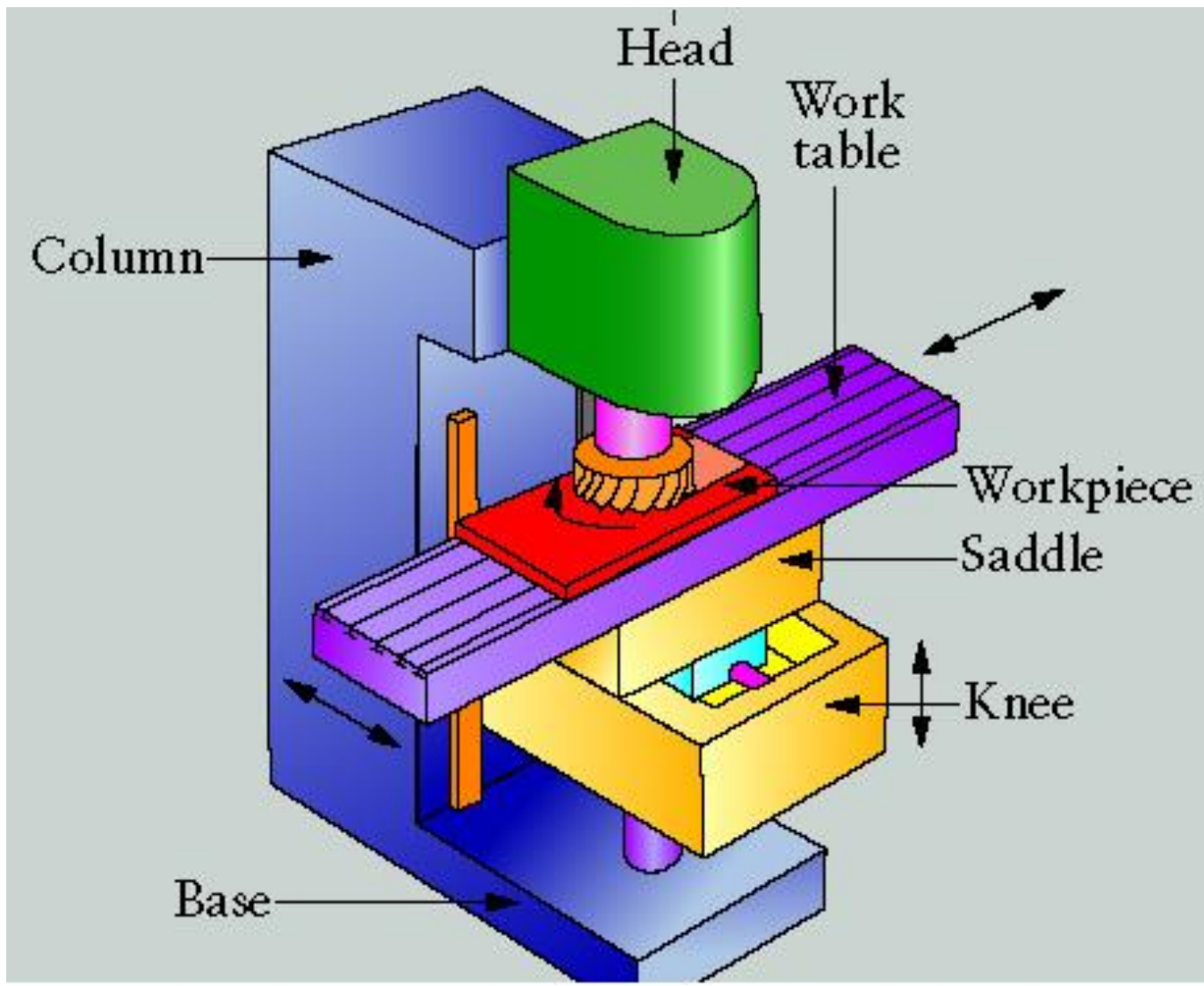

# Milling Operations

- Peripheral Milling: In this milling operation the finished surface is parallel to the axis of the cutter and is machined by cutter teeth located on the periphery of the cutter.
- Face Milling: In face milling, the finished surface is at right angle to the cutter axis and it is obtained by the teeth on the periphery and the flat end of the cutter.

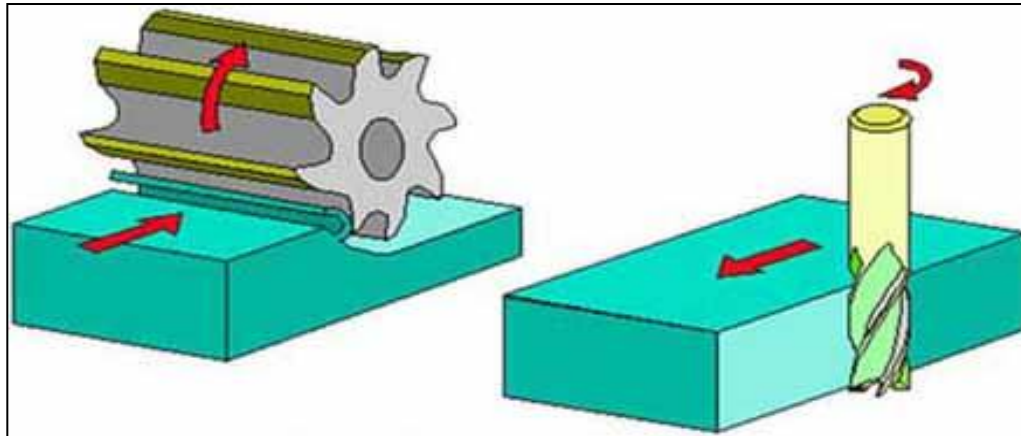

Peripheral Milling

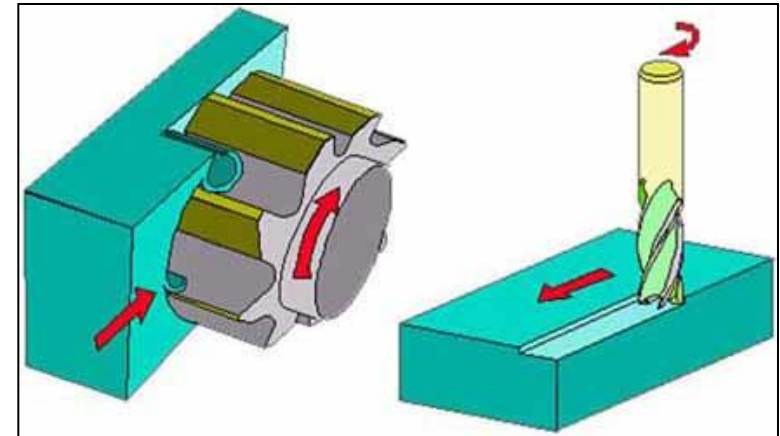

Face Milling



# Peripheral Milling

- Slab Milling: A milling operation that uses a cylindrical mill on an axis parallel to the worktable to create a flat surface.
- Slotting: A milling operation that cuts a narrow ridge into the surface of a workpiece.
- Slitting: A rotary tool-steel cutting tool with peripheral teeth, used in a milling machine to remove material from the workpiece through the relative motion of workpiece and cutter.
- Side Milling: Milling with a side-milling cutter to machine one vertical surface.

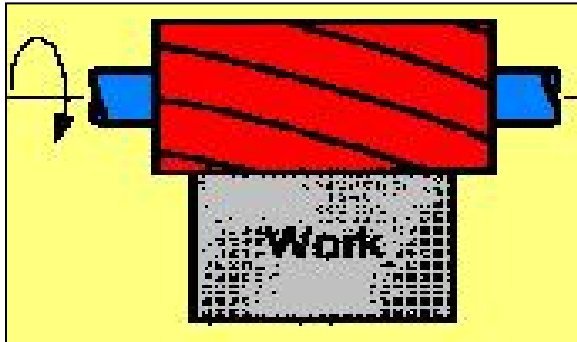

Slab milling

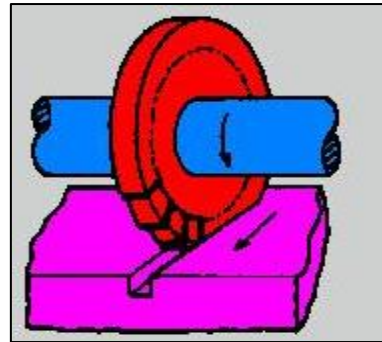

Slotting

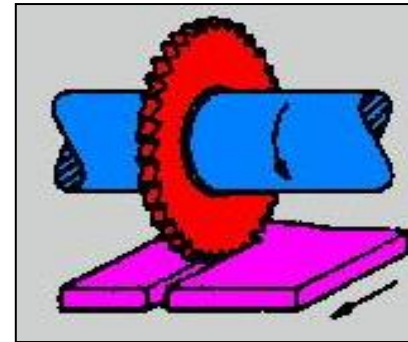

Slitting

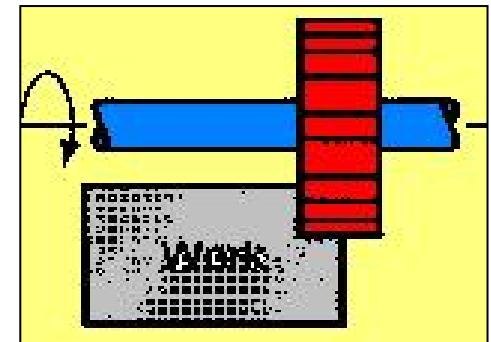

Side milling



- Form Milling: A milling operation that uses a mill with a unique shape to create that shape into the workpiece.
- Straddle Milling: Face milling of two parallel vertical surfaces of a workpiece simultaneously by using two side-milling cutters.

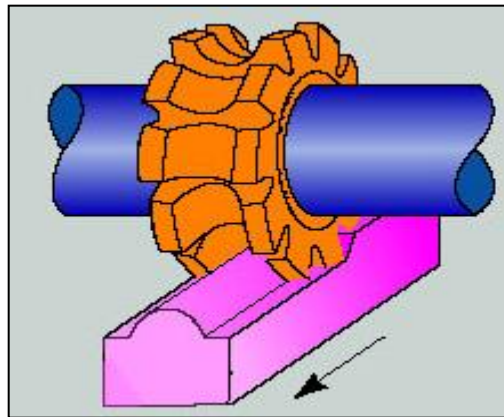

Form milling

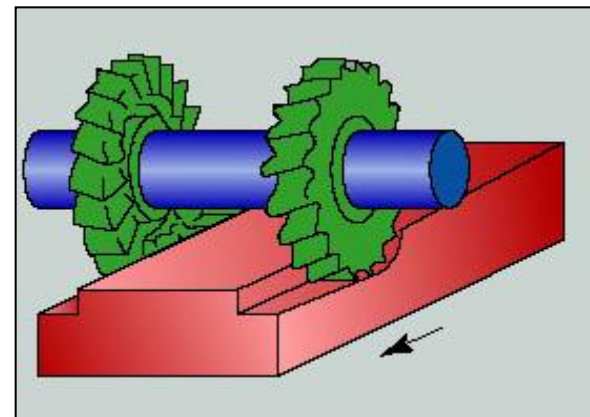

Straddle milling



# Face Milling

- Conventional Milling: The diameter of the cutter is greater than the work part width, so that the cutter overhangs the work on both sides.
- Partial Face Milling: The cutter overhangs the work on only one side.
- End Milling: The cutter diameter is less than the work width, so a slot is cut into the part.
- Surface Contouring: A ball-nose cutter (rather than square end cutter) is fed back and forth across the work along a curvilinear path at close intervals to create a three-dimensional surface form.
- Pocket Milling: Another form of end milling, this is used to mill shallow pockets into flat parts.
- Profile Milling: This is a form of end milling in which the outside periphery of a flat part is cut

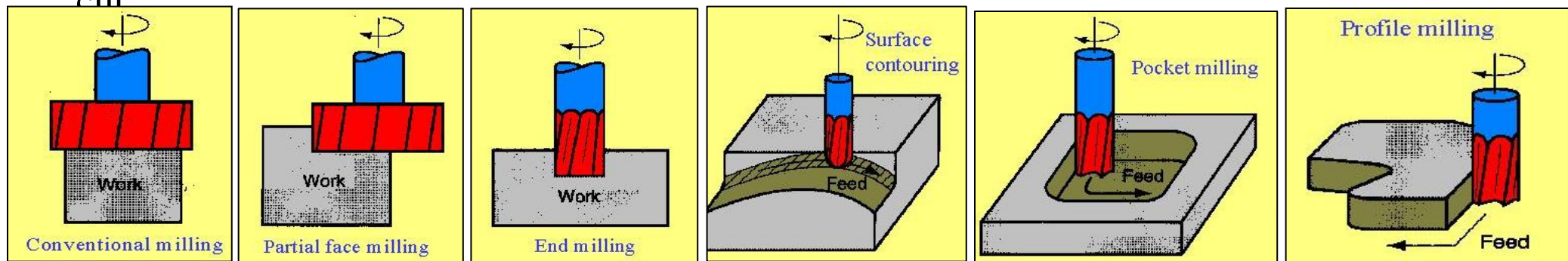

# Cutting Tools for Horizontal Milling

- Slab Mills: For heavy cutting of large and flat surfaces.
- Side and Face Cutters: This type of cutters has cutting edges on the periphery and sides of the teeth for cutting shoulders and slots.
- Slitting Saws: For cutting deep slots or for parting off .
  - Note: Horizontal milling cutters are specified by the name, the material, the width, the diameter, and the hub size of the cutter.
  - For example: Side and face cutter, High Speed Steel, Cutter size :  $10 \times \phi$  100, Hub size:  $\phi$  25

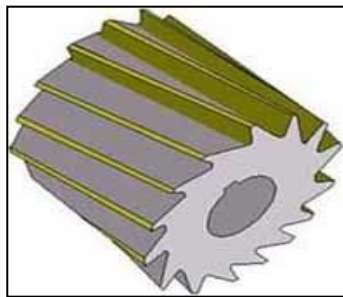

Slab mill

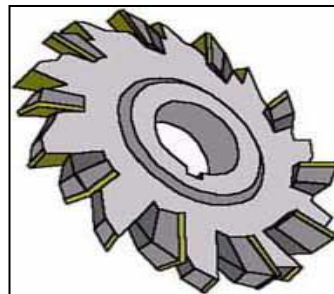

Side and face cutter

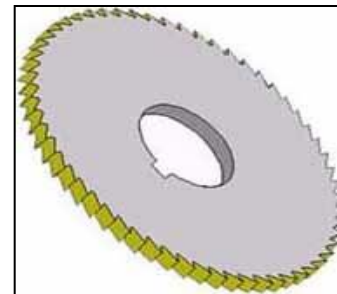

Slitting saw



# Cutting Tools for Vertical Milling

- Rough Cut End Mills: For rapid metal removal.
- End Mills: Commonly used for facing, slotting and profile milling.
- Face Milling Cutters: For heavy cutting.
- Slot Drills: For producing pockets without drilling a hole before hand.
- Note: Most vertical milling cutters are of end mill types and are specified by the **material**, the **diameter**, the **length**, the **helical angle**, the **types of shank** and the **shank diameter**. For face milling cutter, only the diameter of the cutter and the types of carbide inserts are required.

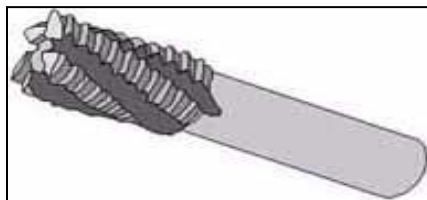

Rough cut end mill

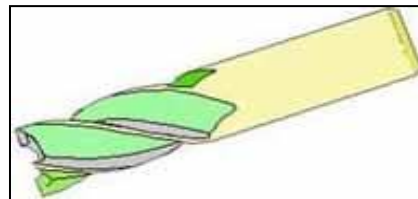

End mill

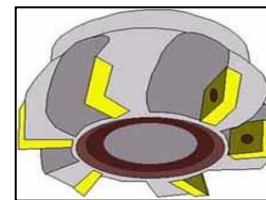

Face milling cutter

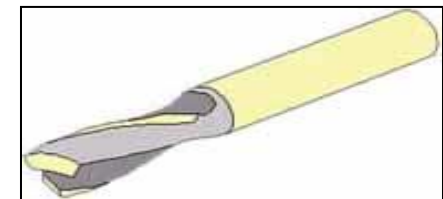

Slot drill



# Industrial Applications

- Milling machines are widely used in the tool and die making industry and are commonly used in the manufacturing industry for the production of a wide range of components. Typical examples are the milling of flat surface, indexing, gear cutting, as well as the cutting of slots and key-ways.
- When equipped with digital readout, the machine is capable of producing more precise work for the manufacturing of plastic moulds, tool & dies, and jigs & fixtures.



---

---

TTT



TTTT



# DRILLING & RELATED OPERATIONS

---

- Drill can be defined as a rotary end cutting tool having one or more cutting lips, and having one or more helical or straight flutes for the passage of chips and the admission of a cutting fluid. Drilling makes up 25% of machining
- The size of a drilling machine may be specified as follows:
  - **Portable drilling machine** is specified by the maximum diameter of a drill which can be held
  - **Sensitive and upright drilling machines** are specified by the diameter of the largest workpiece can be drilled
  - **Radial drilling machine** is specified by the arm and column diameter
  - **Multiple spindle drilling machine** specified by the drilling area, the size and number of holes a machine can drill.



# Classification of Drilling Machines

---

- Portable Drilling Machine
- Sensitive Drilling Machine: Bench mounting and Floor mounting
- Upright Drilling Machine: Light duty and Heavy duty
- Radial Drilling Machine: Plain, Semi-universal and Universal
- Gang Drilling Machine
- Multi-spindle Drilling Machine: Simple unit and Way-type
- Automatic Production Drilling Machine: Indexing type and Transfer type
- Deep-hole Drilling Machine: Vertical and horizontal



- Sensitive Drilling Machine: It is a light , simple and high speed machine similar to the ordinary upright drilling machine. It mainly consists of column, table, base and spindle. Hand feed is given by means of a rack and pinion drive. These machines may be driven directly by motor, by a belt, or by means of a friction disk. It is suitable only for light work and are seldom capable of rotating drills over 15 mm diameter. Sensitive drilling machines may be mounted on the bench or on the floor.

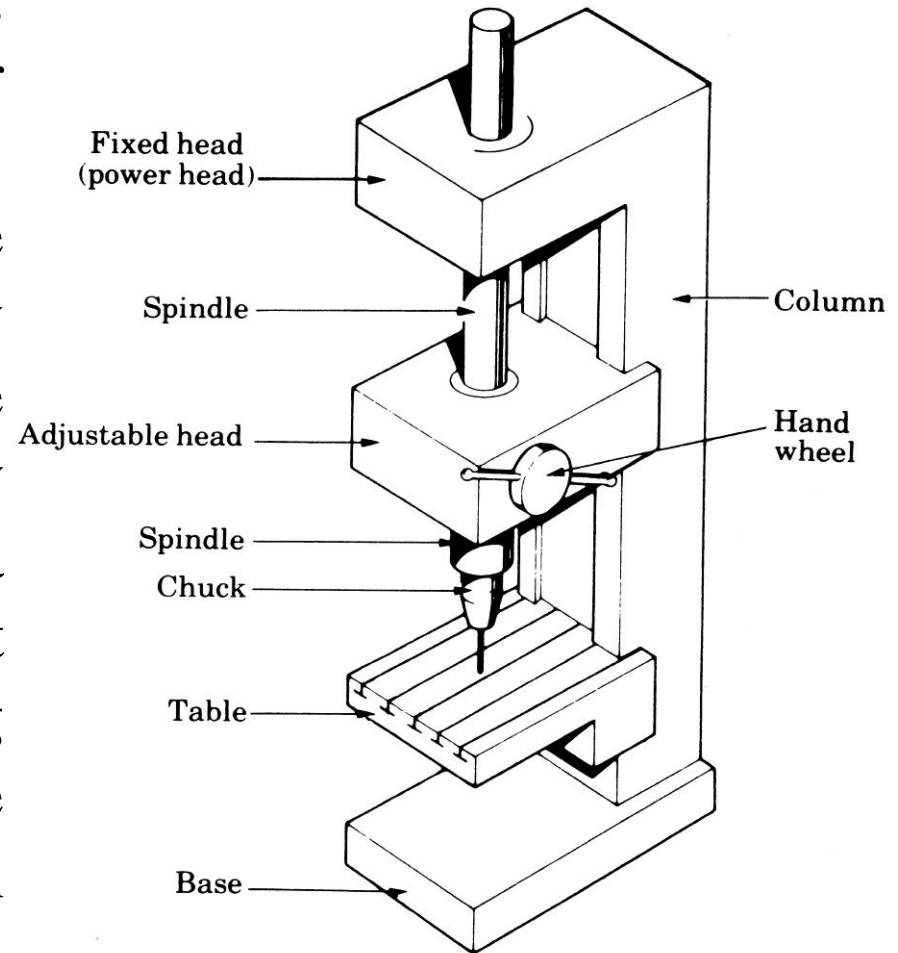

- [Upright Drilling Machines](#): It is similar to sensitive drilling machine except that it has power feeding mechanism for the rotating drill. It has several spindle speeds offered in several speed ranges from 75 to 3500 rpm. The feed rates are controlled by a single feed lever. It is used when numerous drilling operation are required in rapid succession, turret rotates needed tool into position for each operation. This mechanism can be used for tapping as well as for drilling.



- Radial Drilling Machines: It is largest and most versatile drilling machine. It consists of a vertical column with a radial arm which carries the drilling head. The arm may be swung around to any position over the work table. The drilling head has a radial adjustment along this arm. These adjustments permit the operator to locate the drill quickly over any point on the work. It is used on large workpieces, spindle mounts on radial arm, allowing drilling operations anywhere along the arm length



- Gang-Drilling Machines: In a gang drilling machine, several drilling spindles are mounted on a single table. Such a machine is useful when a workpiece is to have several operations performed, such as drilling, counter boring etc. or drilling holes of several different sizes. Fast movement of the workpiece from the spindle to another is an important feature of this machine. The spindles are lined up in a row, and driven either independently or together. There may be many spindles in a gang drilling machine, but four spindles are the most common.

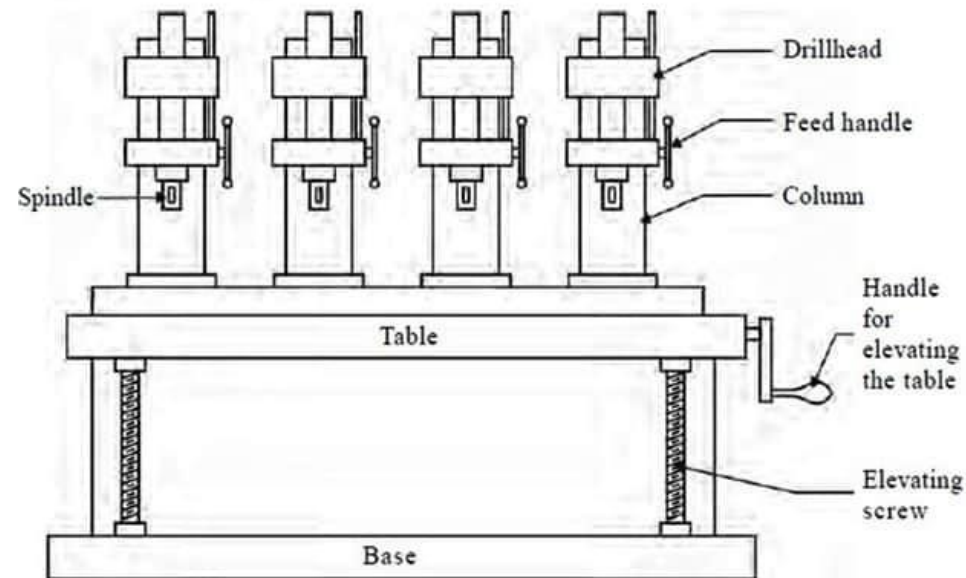

- Multi-spindle Drilling Machines: Multi-spindle drilling machines are essentially production machines developed for drilling several holes simultaneously. These machines when once setup will drill many parts with great accuracy. Drilling jigs are sometimes required to guide the drills accurately into the work. These machines differ principally in the way the drills are held and in the way the feed is accomplished. The drilling cycle consists of rapid advance of drills to the work, proper feed and rapid return of drills to starting position.

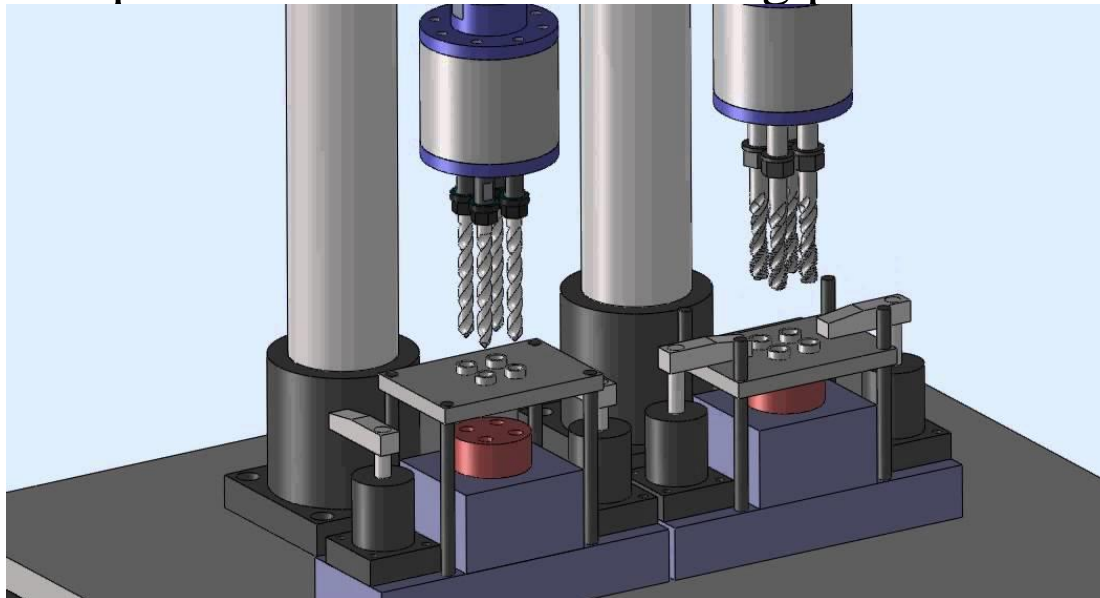

# Operations on a Drilling Machine

- Reaming: Reaming is used to slightly enlarge a hole, to provide a better tolerance on its diameter and to improve its surface finish. The tool is called a reamer and it usually has straight flutes.
- Tapping: This operation is performed by a tap and is used to provide internal screw threads on an existing hole.
- Counterboring: Counterboring provides a stepped hole, in which a larger diameter follows a smaller diameter partially into the hole. A counterboring hole is used to seat bolt heads into a hole so the heads do not protrude above the surface.

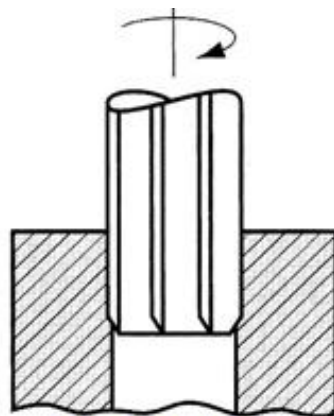

Reaming

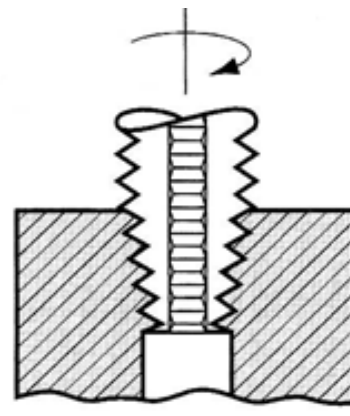

Tapping

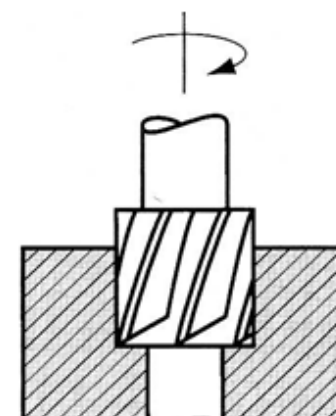

Counterboring



- Countersinking: This is similar to Counterboring, except that the step in the hole is cone-shaped for flat head screws and bolts.
- Centering: Also called center drilling, this operation drills a starting hole to accurately establish its location for subsequent drilling. This tool is called a centerdrill.
- Spotfacing: Spotfacing is similar to milling. It is used to provide a flat machined surface on the workpart in a localized area.

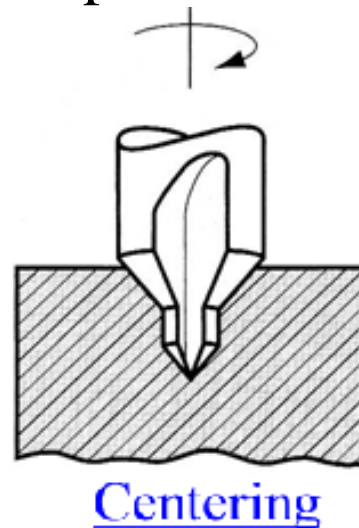
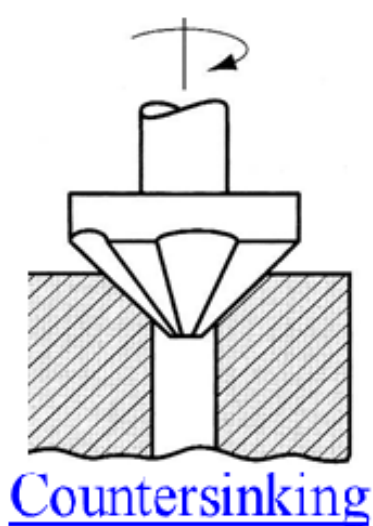

# Geometry of a Twist Drill

- The drill has been designed to be an efficient cutting tool. It is composed of the three principal parts.
- **Point:** Point is the cone shaped end and does the cutting. It consists of (i) dead center, (ii) lips (iii) heel and (iv) lip clearance.
- **Shank:** This is the portion which is clamped to provide the drive. Straight shank for drill up to 1/2". Shank is equal to body diameter. Above 1/2", shank can be tapered or reduced.
- **Body:** It is the portion between the point and the shank. The body consists of (i) flutes, (ii) margin, (iii) body clearance and (iv) web.

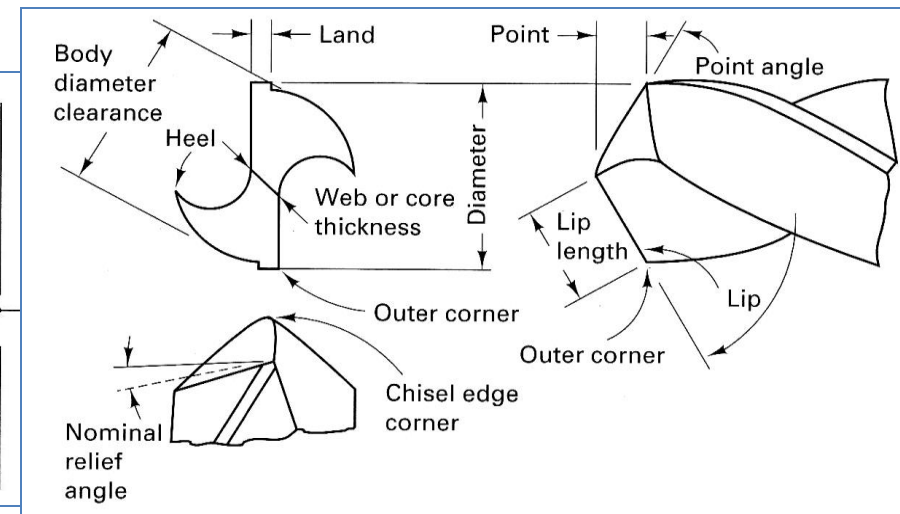
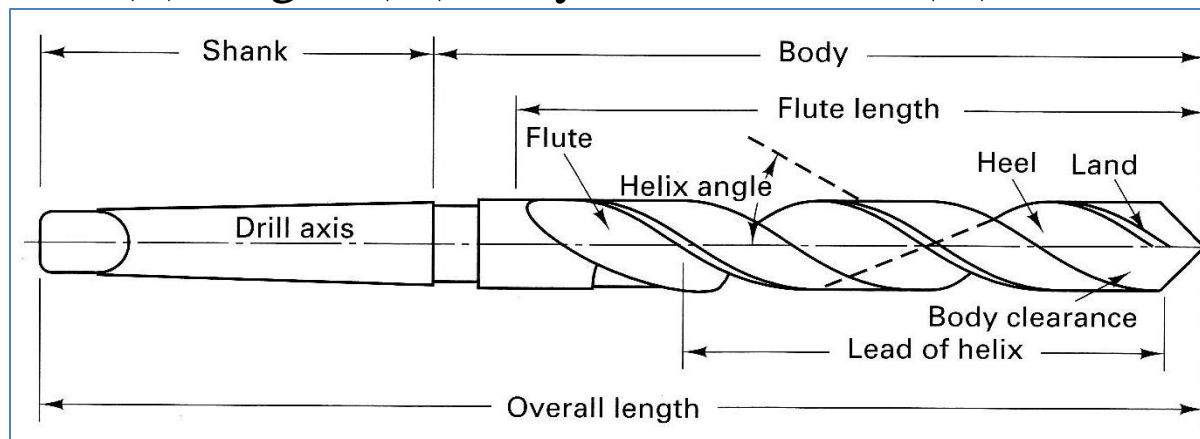

# Classifications of Drills

---

---

- Classification Based on Construction: Solid Drills, Tipped Solid Drills & Composite Drills
- Classification Based on Methods of Holding or Driving: Straight Shank Drills, Taper Shank Drills, Taper Shank Square Drills, Shell Core Drills, Threaded Shank Drills and Beaded Shank Bits
- Classification Based on Number of Flutes: Two-Flute Drills, Single-Flute Drills, Three-Flute Drills (Core Drills) and Four-Flute Drills (Core Drills)
- Classification Based on Hand of Cut: Right-Hand Cut and Left-Hand Cut



# Cutting Tools for Drilling Operations

- Twist Drill: The twist drill is the most common type of drill. It has two cutting edges and two helical flutes that continue over the length of the drill body. The drill also consists of a neck and a shank that can be either straight or tapered.
- A tapered shank is fitted by the wedge action into the tapered socket of the spindle and has a tang that goes into a slot in the spindle socket, thus acting as a solid means for transmitting rotation. Straight shank drills are held in a drill chuck that is, in turn, fitted into the spindle socket in the same way as tapered shank drills.



- Core Drill: A core drill consists of the chamfer, body, neck and shank. This type of drill may have three or four flutes and an equal number of margins, which ensures superior guidance, thus resulting in high machining accuracy.
- Spade Drill: A spade drill is used for drilling large holes of 90 mm or more. The design of this type of drill results in a marked saving in tool cost as well as in tangible reduction in tool weight that facilitates its ease of handling. Moreover, this drill is easy to grind.



Core Drill



Spade Drill



- **Step Drill**: A multiple diameter drill with one set of drill lands which are ground to different diameters
- **Gun Drill**: A gun drill is used for drilling deep hole. All gun drills are straight fluted, and each has a single cutting edge. A hole in the body acts as a conduit to transmit coolant under considerable pressure to the tip of the drill.
- **Center Drill**: Center drill bits are used in metalworking to provide a starting hole for a larger-sized drill bit or to make a conical indentation in the end of a workpiece in which to mount a lathe center.



Step Drill



Gun Drill

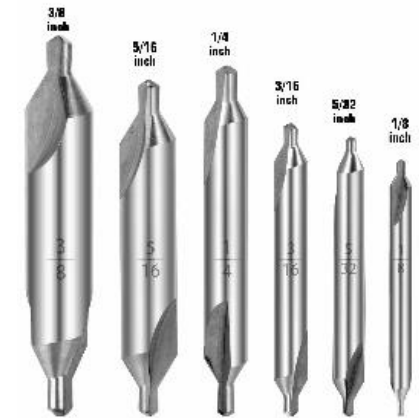

Centre Drill



# SHAPING AND RELATED OPERATIONS

- A shaper is a machine having reciprocating cutting tool and the fixed workpiece. The tool traverses the workpiece and feeds over at the end of each stroke. The tool is clamped in the tool post and the workpiece on the table. The function of the shaper is, primarily, the production of flat surfaces. By means of special tools, attachments and devices for holding the workpiece, a shaper can also be used to cut external and internal keyways, spiral grooves, gear racks, dovetails, T-slots and other miscellaneous shapes.

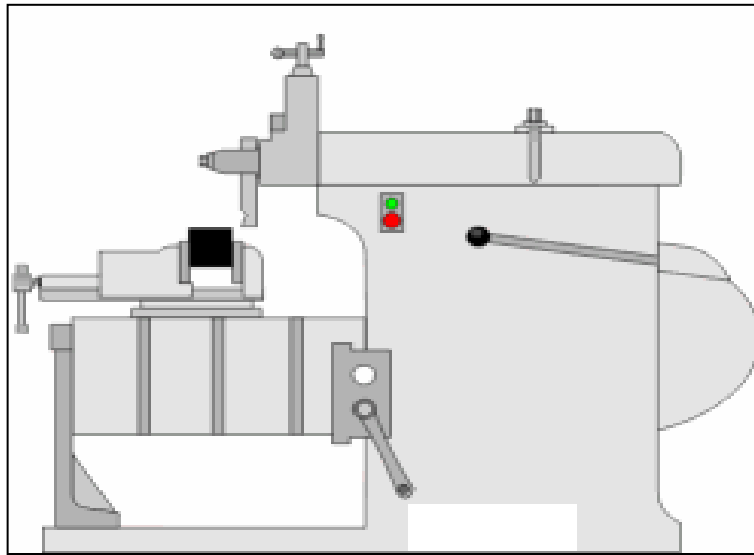

# Common Shaping and Planing Geometry

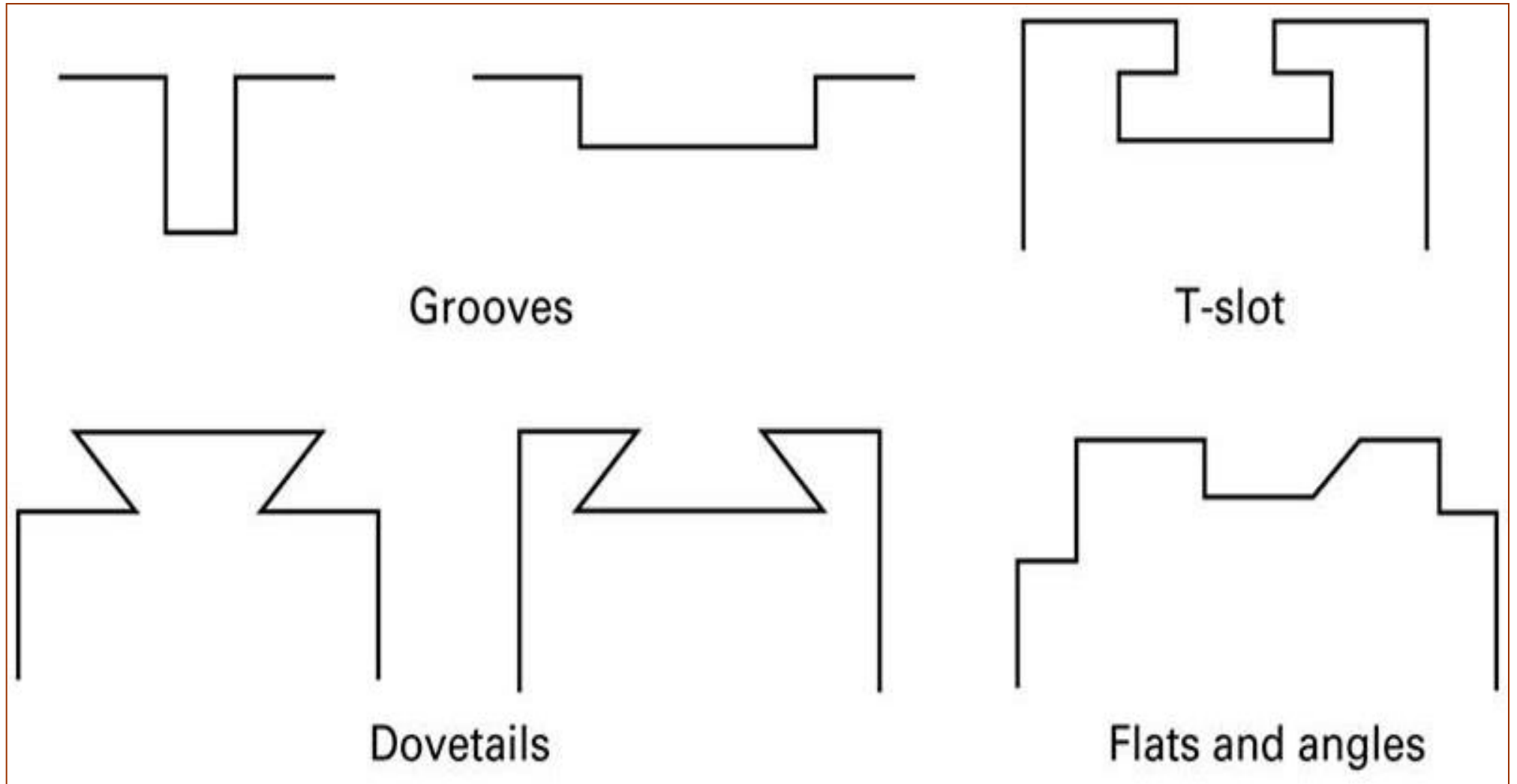

# Horizontal Push Cut Shaper

- **Base**: The base is the necessary bed or support required for all machine tools. All other parts are mounted on and above the base. The shaper is installed by rigidly bolting the bed to the shop floor.
- **Column**: The column of the shaper is a hollow casting and is mounted on the base. It houses the drive mechanism for the ram and the table. At the top of the column, the bearing surfaces known as guide ways are provided on which the ram reciprocates.
- **Saddle**: The saddle moves up and down (Y axis), usually manually, to set the rough position of the depth of cut. Final depth can be set by the hand crank on the tool head.
- **Table**: The table is moved left and right, usually by hand, to position the work under the cutter when setting up. Then, either by hand or more often automatically, the table is moved sideways to feed the work under the cutter at the end or beginning of each stroke.
- **Ram**: The ram slides back and forth in dovetail or square ways to transmit power to the cutter. The starting point and the length of the stroke can be adjusted.



- **Tool Head**: It is fastened to the front end of the ram and consists of tool slide, tool post and clapper box. It can be swiveled to any angle to enable the tool to make angular cuts. The holder rests in a clapper box which is a means of hinging the tool. This provision is made in order to allow the tool to swing up on the return stroke.
- **Clapper Box**: The clapper box is needed because the cutter drags over the work on the return stroke. The clapper box is hinged so that the cutting tool will not dig in. Often this clapper box is automatically raised by mechanical, air, or hydraulic action.

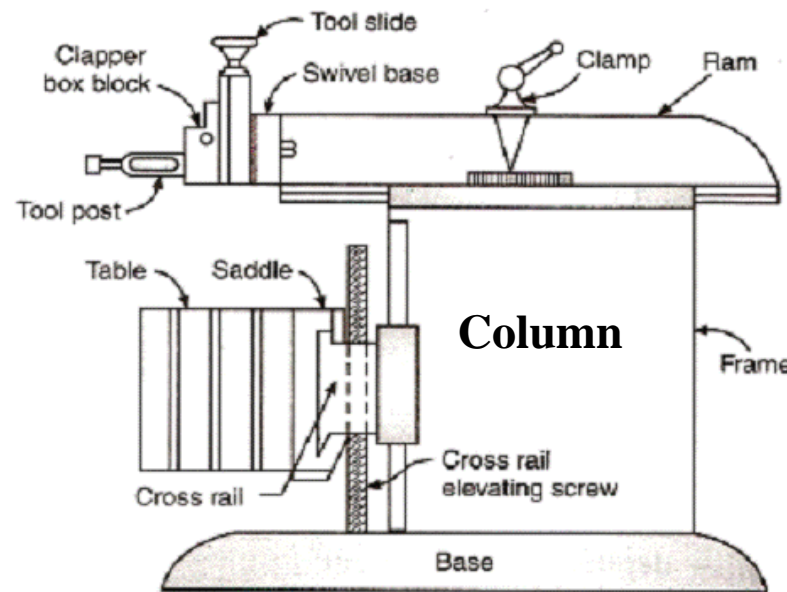

# Quick Return Mechanism

- In shaper, the cutting operation is done in forward stroke only, the backward stroke is idle and therefore wastage. The time required for backward stroke must be minimized. It must be completed as quickly as possible. This is achieved by quick return mechanism.

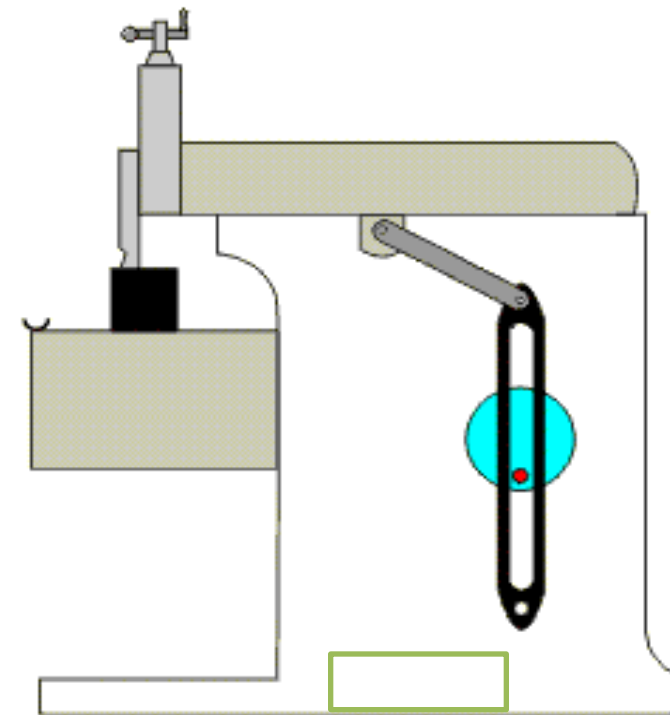
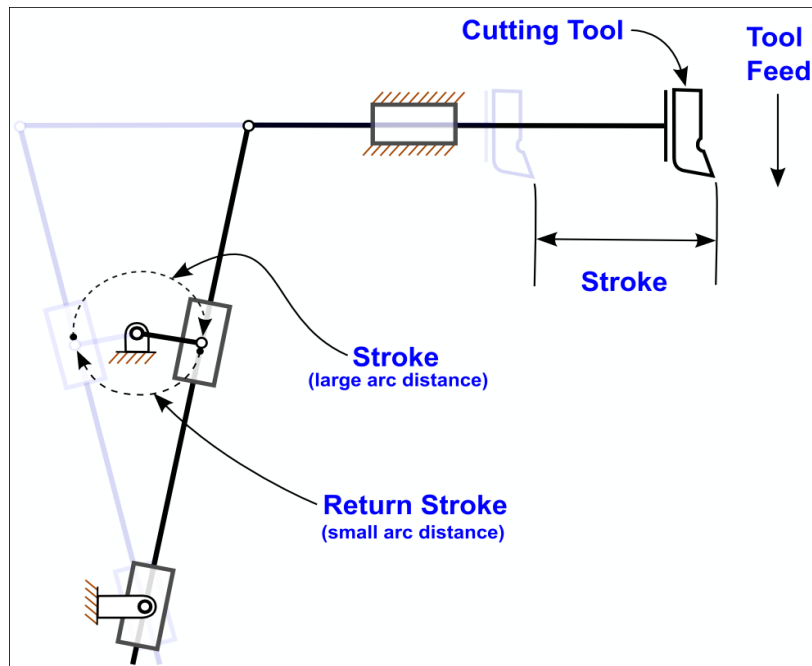

THE SHAPING MACHINE



# Types of Work

The tool post and the tool slide can be angled as seen below. This allows the shaper to be used for different types of work

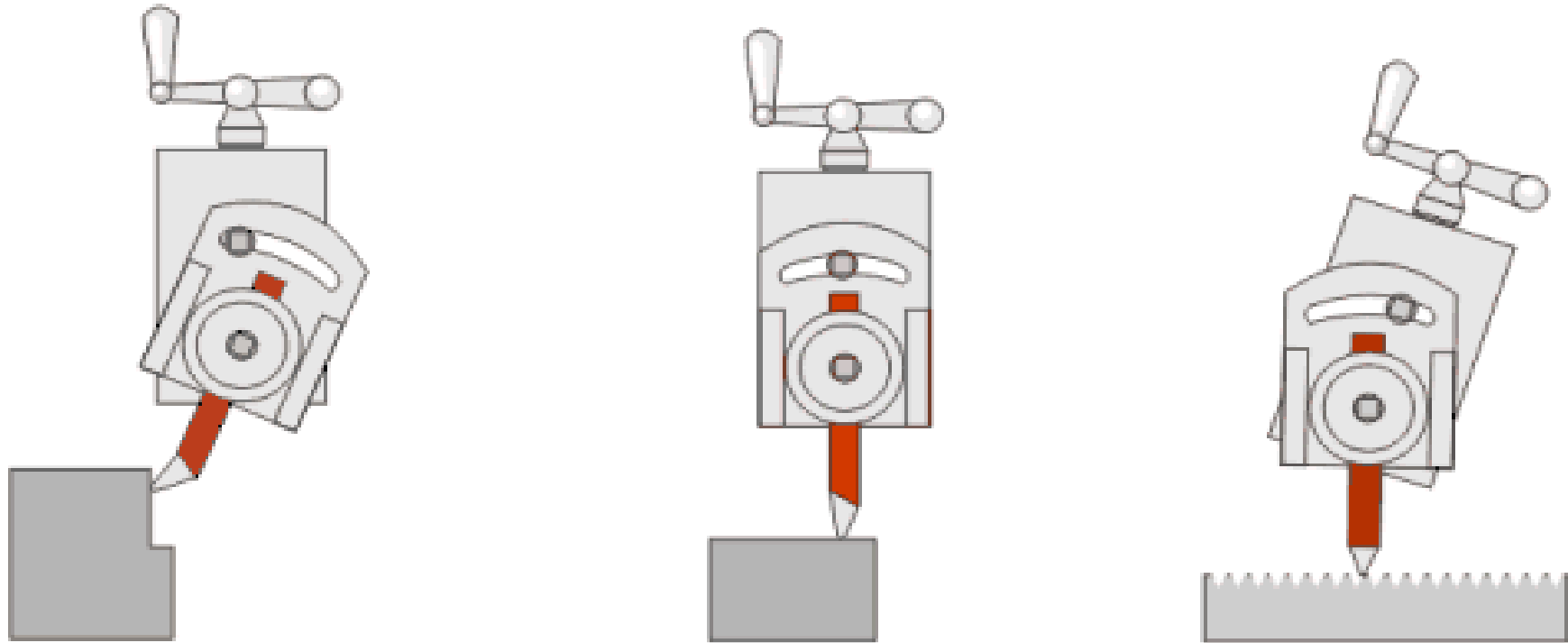

# Planing Machines

- A planer is a machine having reciprocating work and fixed tool. The work traverses the tool and feeds over at the end of each stroke. The tool is clamped in the tool holder and the work on the table. The type of work is very similar to that done on a shaper except that a planer is adopted to much large work.
- Difference between Planer and Shaper
  - The planer is a very heavy and robust machine in construction, the shaper is smaller one.
  - On planer the work is moved against the stationary tool, on shaper the tool is moved against the stationary work
  - On planer the feed is given to the tool, on shaper the feed is given to the work
  - In planer, the work table is driven either by gear or by hydraulic means. The shaper ram can also be driven in this manner, but in most cases the quick return mechanism is used
  - Most planer differ from shaper in that they approach constant velocity cuts
  - The planer is specially adopted to large work, the shaper can do only small work.



# Types of Planer

- Double-Housing Planer: It consists of a long heavy base on which the table or platen is reciprocated. The upright housing is located at the side of the base near the center to support the cross rail. The cross rail supports the tool heads. The tool may be fed manually or by power in either a vertical or a crosswise direction. The motor drive is usually at one side of the planer near the center and the drive mechanism is located under the table. The controls for operation are all at the upright housing.

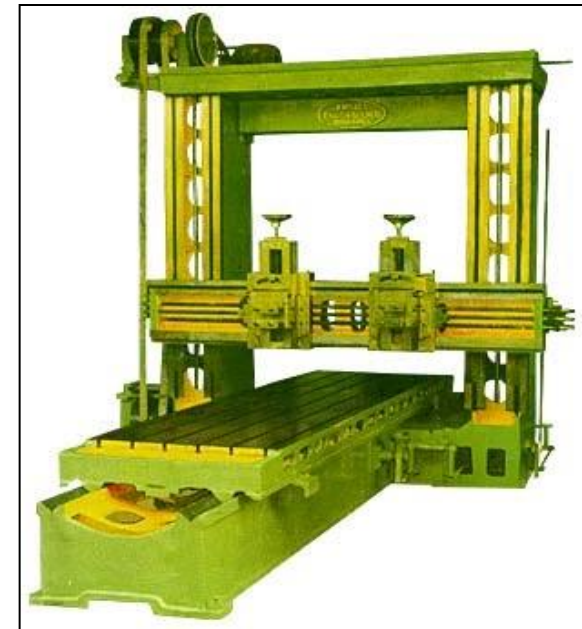
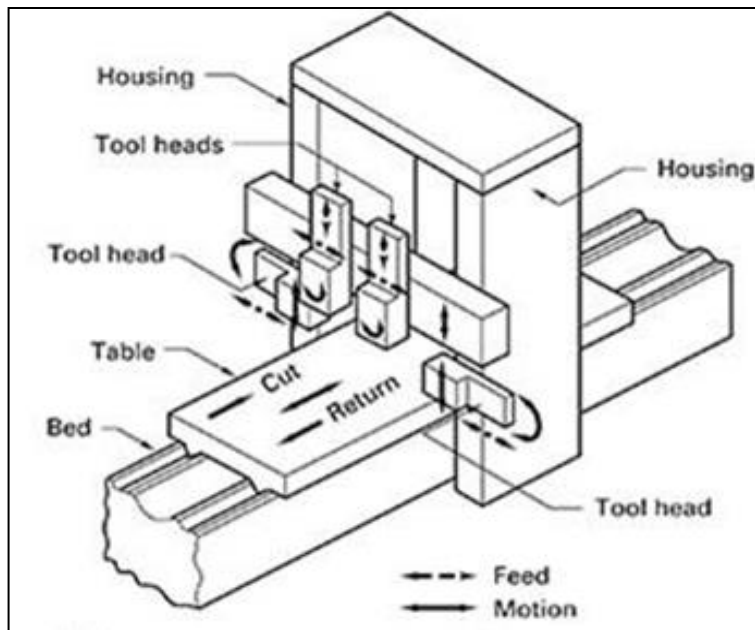

- Open-Sided Planer: The open sided planer has housing on one side only. It is hydraulically driven and used to handle wide work. It can be equipped with duplicating attachments for machining irregular surface. On one side of the table, a master form is mounted so that as the tracer moves over the surface, the cutting tool is moved accordingly. Such devices are usually hydraulically operated and are similar in operation to duplicating units used on other machine tools.

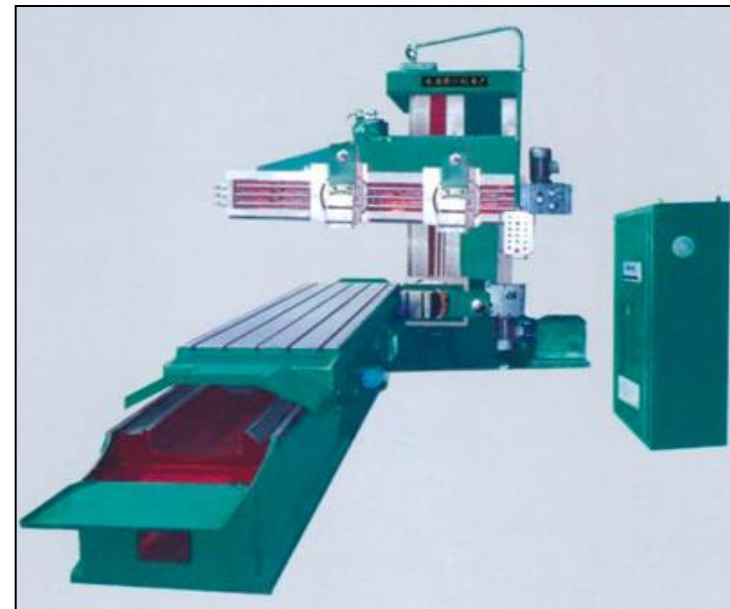
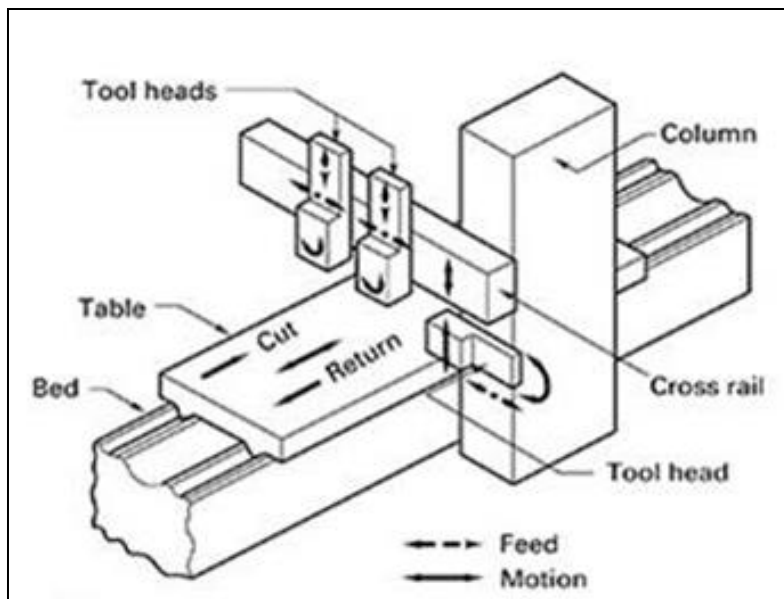

# GRINDING & RELATED OPERATIONS

---

- Grinding is generally considered as a finishing operation. The grinding process consists of removing material from the workpiece by the use of a rotating wheel that has a surface composed of abrasive grains. Grinding is considered to be the most accurate of the existing machining processes. Grinding processes are used when high accuracies, close dimensional tolerances, and a fine surface finishes are required. Grinding processes also allow for high production rates. This allows for a lowered cost of production. Hard materials can also be machined.
- Grinding may be classified as non-precision or precision, according to purpose and procedure.
  - **Non-precision grinding** is concerned where the accuracy and surface finish are of secondary importance.
  - **Precision grinding** is concerned with producing good surface finishes and accurate dimensions.



# Grinding Machines

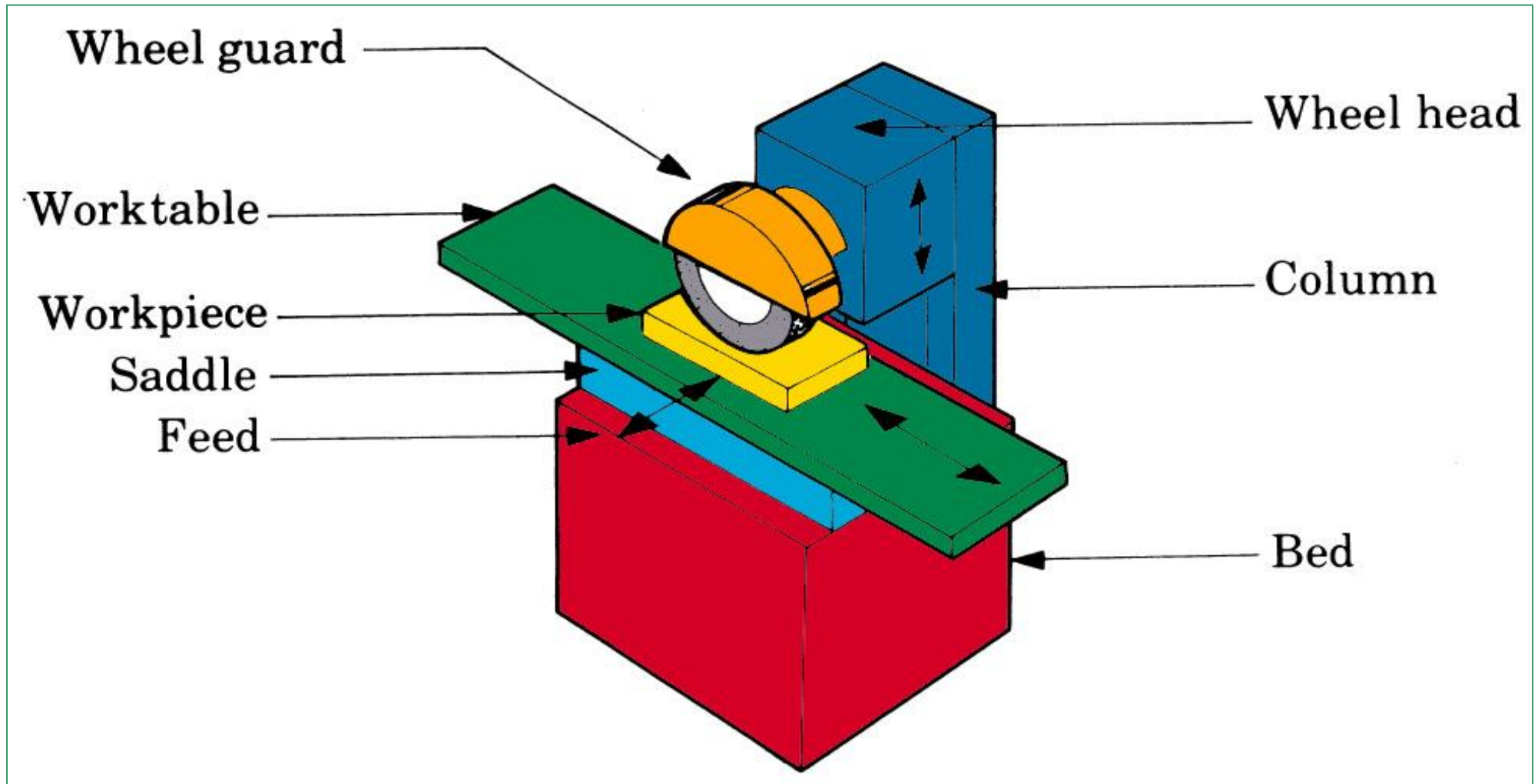

**Horizontal-Spindle Surface Grinder**



- **Surface grinding** is most common of the grinding operations. A rotating wheel is used in the grinding of flat surfaces. Types of surface grinding are vertical spindle and rotary tables.

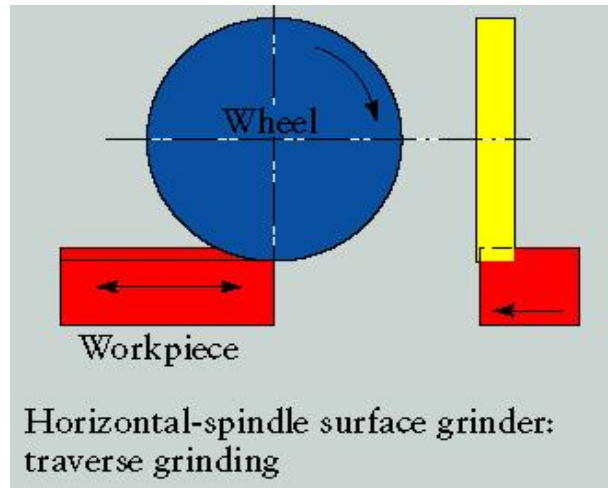

Traverse grinding with a horizontal-spindle surface grinder.

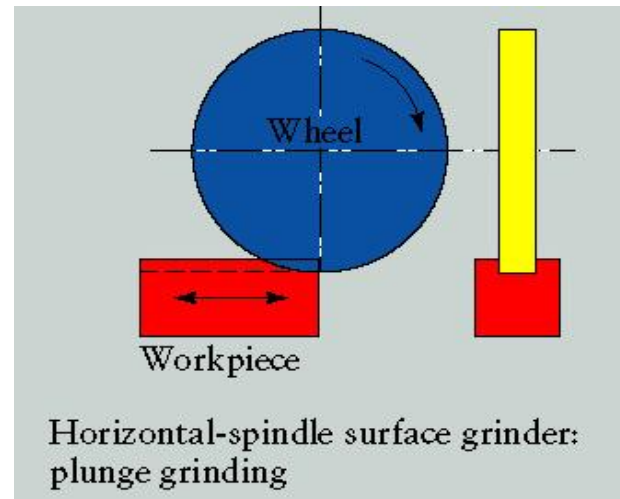

Plunge grinding with a horizontal-spindle surface grinder, producing a groove in the workpiece

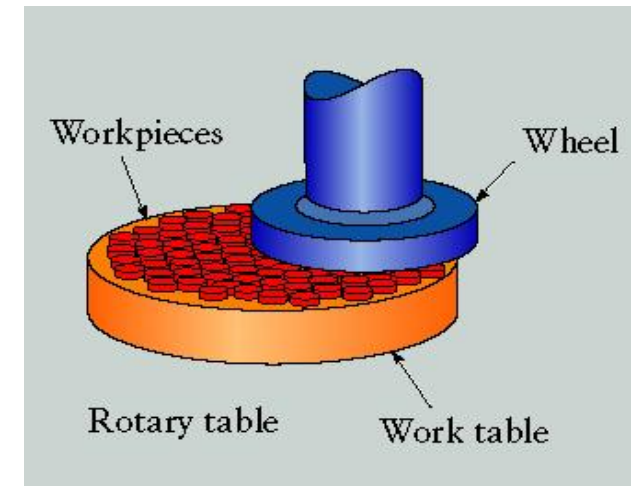

Vertical-spindle rotary-table grinder.



- **Cylindrical grinding** is also called center-type grinding and is used in the removing the cylindrical surfaces and shoulders of the workpiece. Both the tool and the workpiece are rotated by separate motors and at different speeds. The axes of rotation tool can be adjusted to produce a variety of shapes.

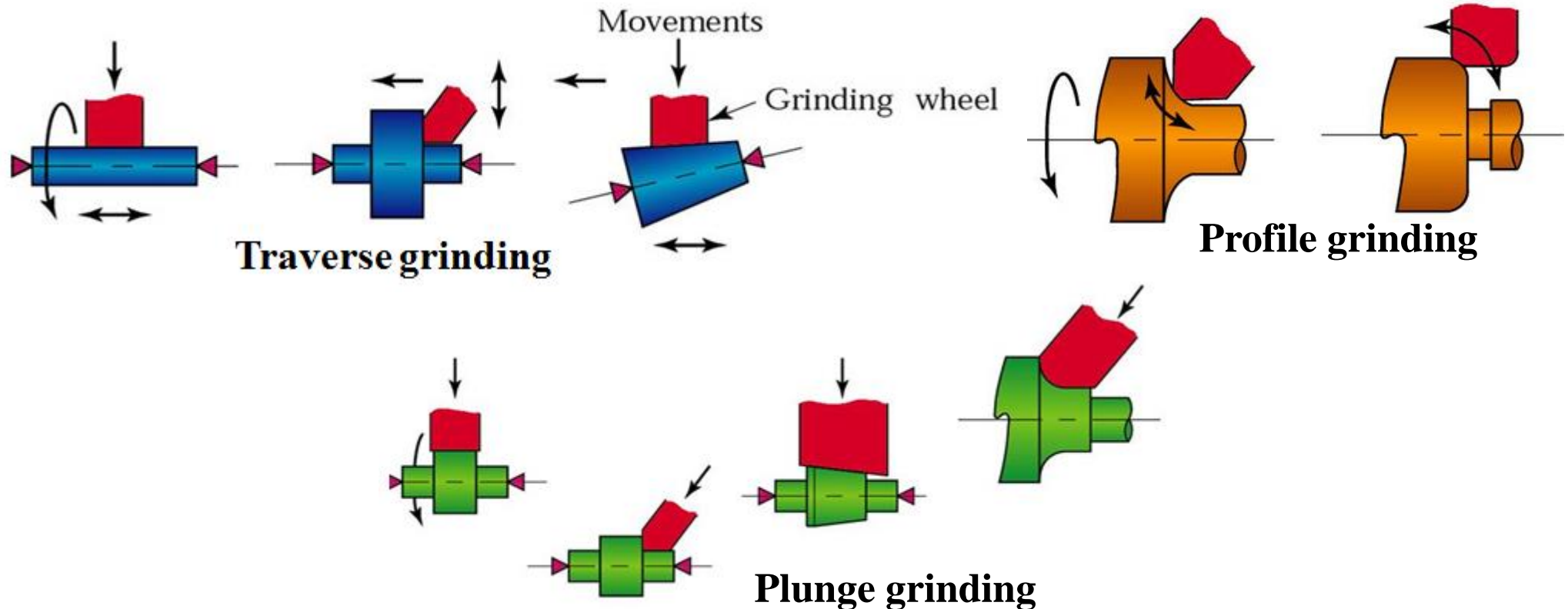

- **Internal grinding** is used to grind the inside diameter of the workpiece. Tapered holes can be ground with the use of internal grinders that can swivel on the horizontal.

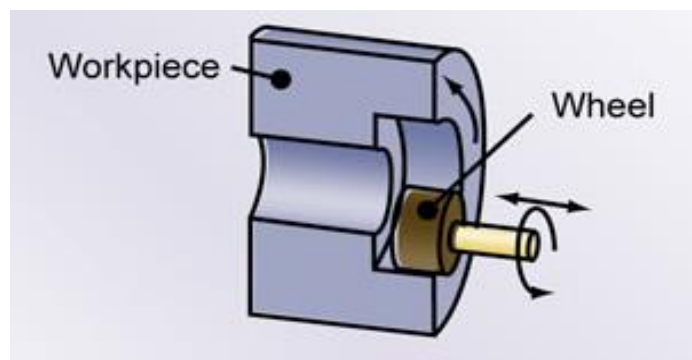
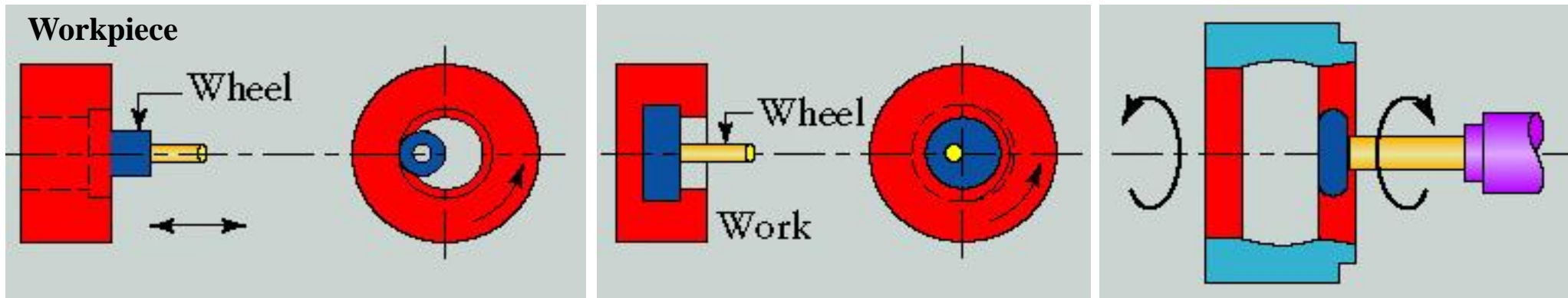

Traverse grinding

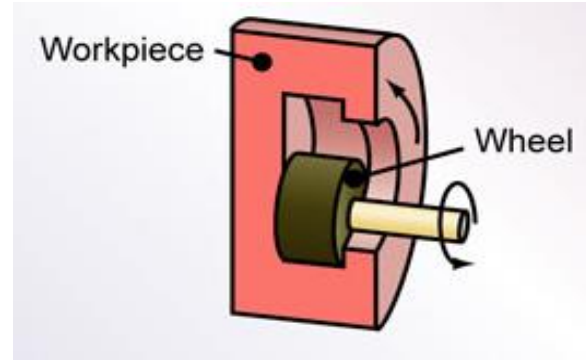

Plunge grinding

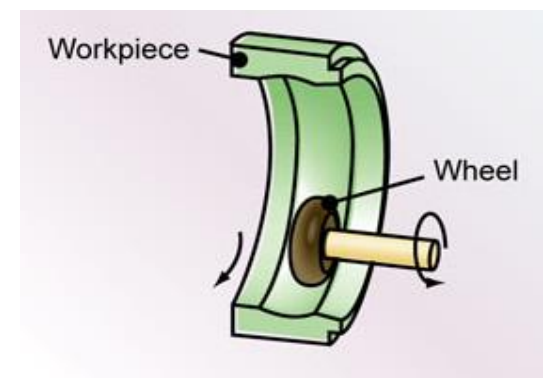

Profile grinder



- **Centerless grinding** is when the workpiece is supported by a blade instead of by centers or chucks. Two wheels are used. The larger one is used to grind the surface of the workpiece and the smaller wheel is used to regulate the axial movement of the workpiece. Types of centerless grinding include through-feed grinding, in-feed/plunge grinding, and internal centerless grinding.

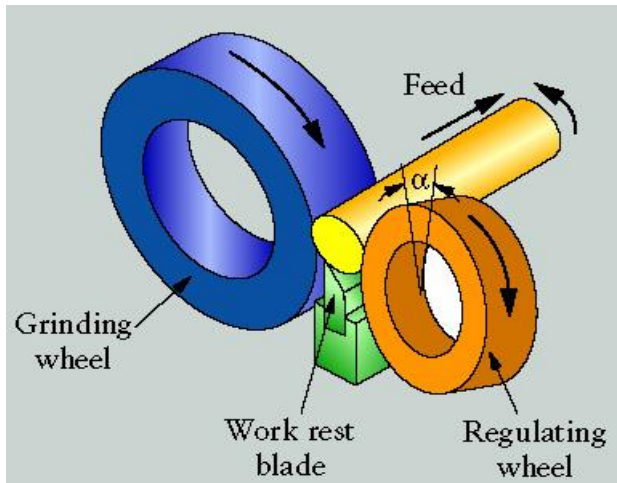

Through feed grinding

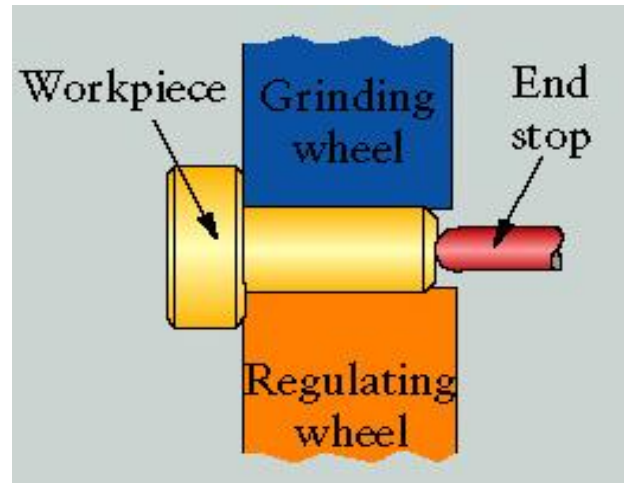

Plunge grinding

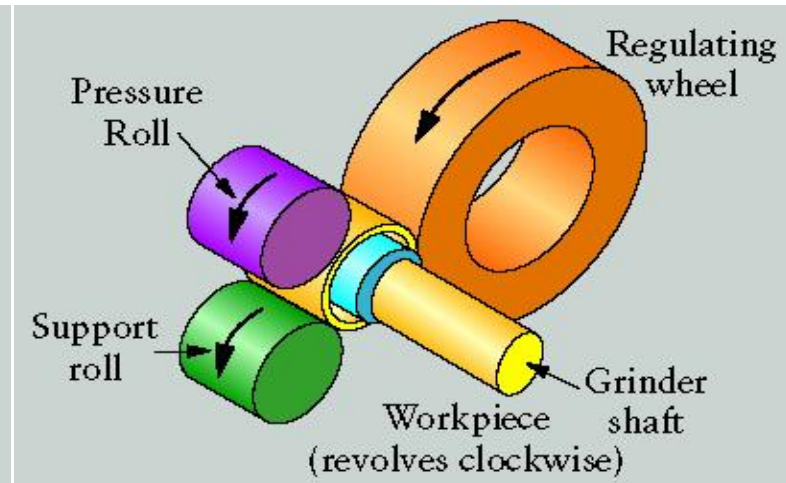

Internal centerless grinding



- **Creep-feed grinding** is used for high rates of material removal. Depths of cut of up to 6 mm are used along with low workpiece speed. Surfaces with a softer-grade resin bond are used to keep workpiece temperature low and an improved surface finish.

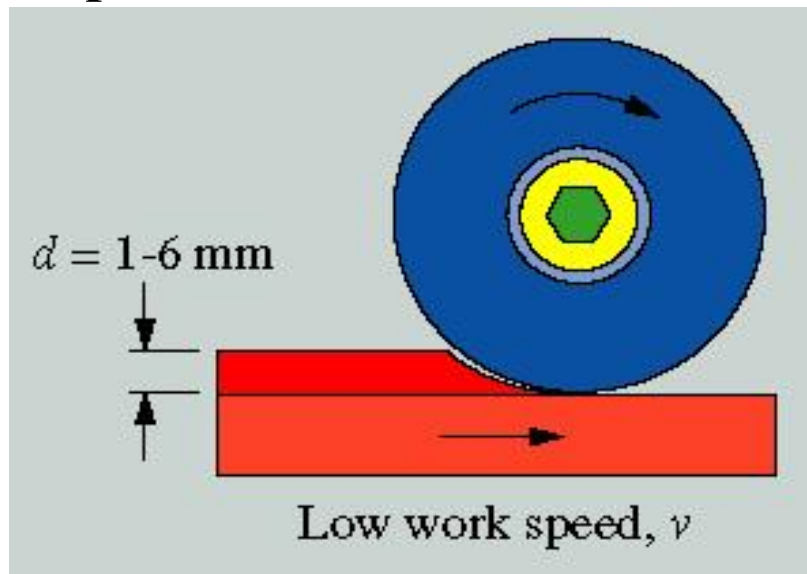

Schematic illustration of the creep-feed grinding process. Note the large wheel depth of cut.

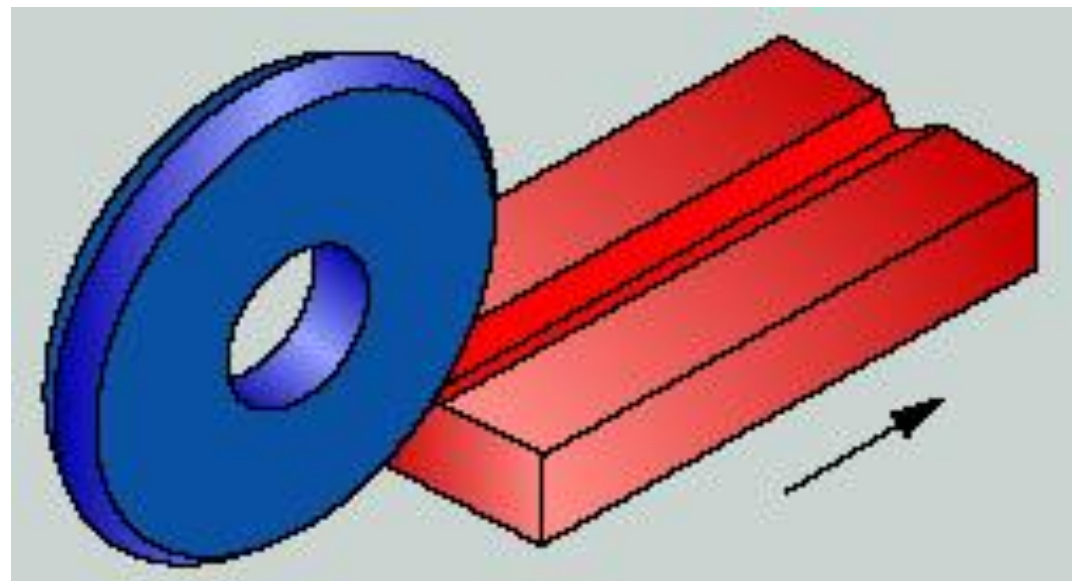

A shaped groove produced on a flat surface in one pass by creep-feed grinding. Groove depth can be on the order of a few mm.



# Common Grinding Wheels

- A grinding wheel is made of abrasive grains held together by a bond. These grains cut like teeth when the wheel is revolved at high speed and is brought to bear against a work piece. The properties of a wheel that determine how it acts are the kind and size of abrasive, how closely the grains are packed together and amount of the bonding material.

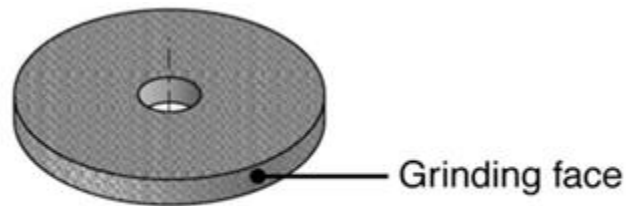

Type 1 — straight

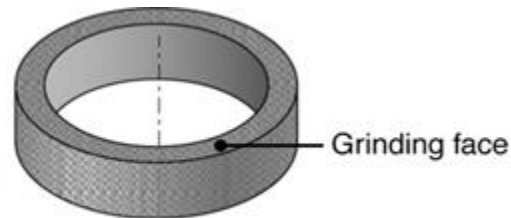

Type 2 — cylinder

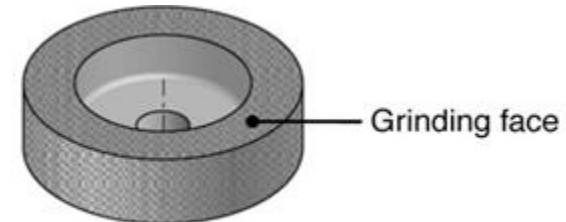

Type 6 — straight cup



Mounted

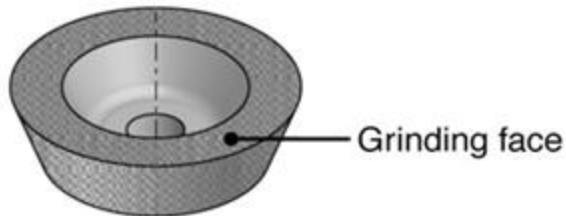

Type 11 — flaring cup

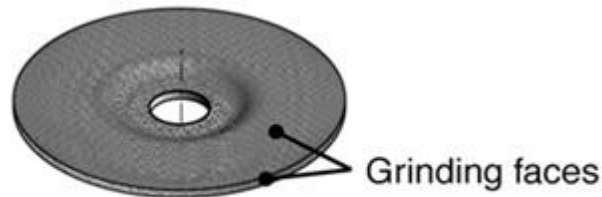

Type 27 — depressed center

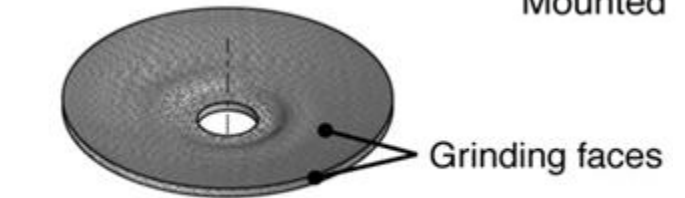

Type 28 — depressed center



# Identifying Grinding Wheels

## ■ Aluminum-Oxide and Silicon-Carbide Bonded Abrasives

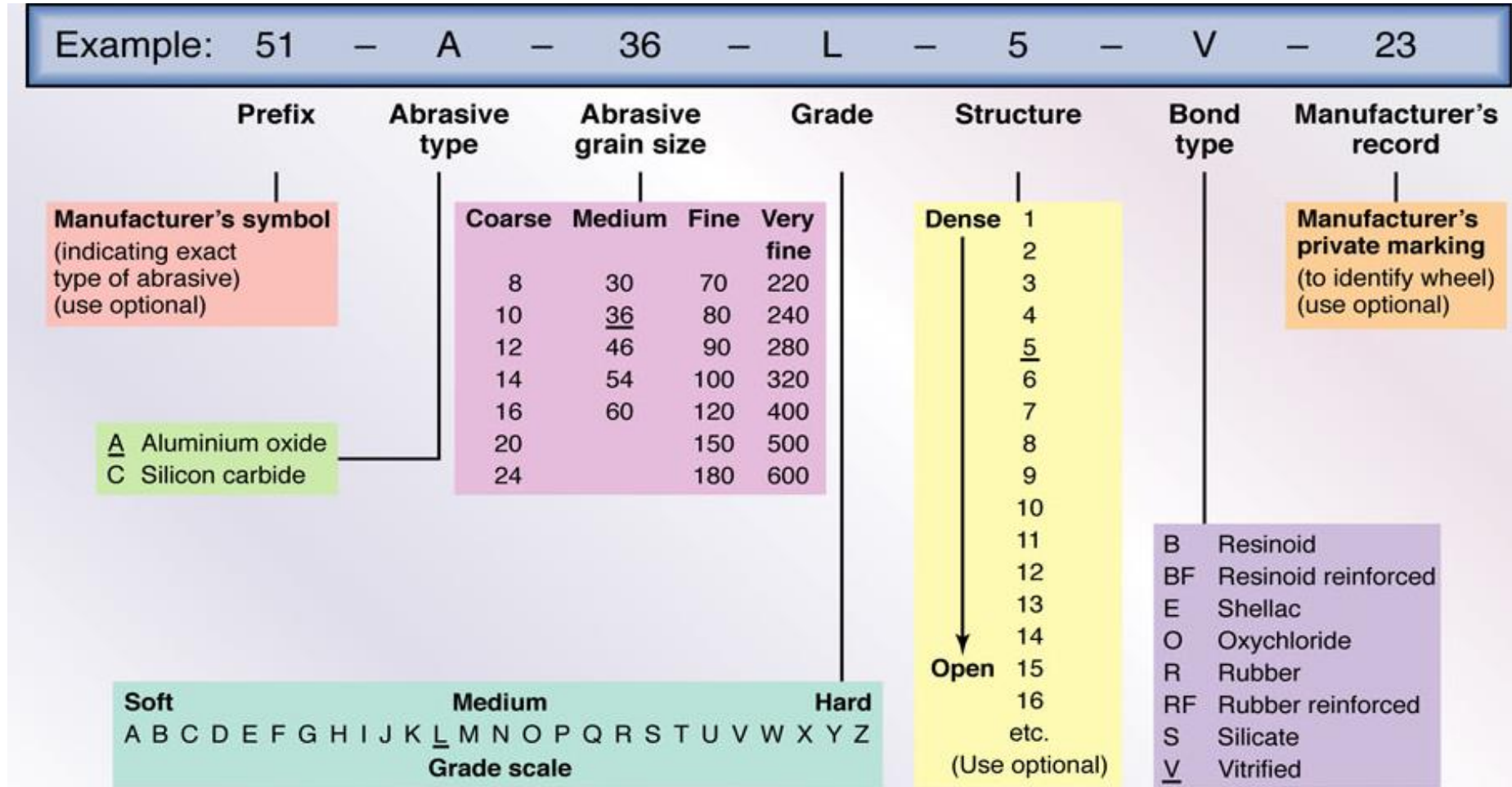

## ■ Cubic-Boron-Nitride and Diamond Bonded Abrasives

Example: M D 100 – P 100 – B 1/8							
Prefix	Abrasive type	Grit size	Grade	Diamond concentration	Bond	Bond modification	Diamond depth (in.)
<b>Manufacturer's symbol</b> (to indicate type of diamond)	B Cubic boron nitride D Diamond	20	A (soft)   to   Z (hard)	25 (low) 50 75 <u>100</u> (high)	B Resinoid M Metal V Vitriified	A letter or numeral or combination (used here will indicate a variation from standard bond)	1/16
		<u>100</u>					<u>1/8</u>
	120	1/4					
	150	Absence of depth symbol indicates solid diamond					
	180						
	220						
	240						
	280						
	320						
	400						
	500						
	600						
	800						
	1000						

